

FARAD

BS 065

TOYOTA IQ 2008 >

3

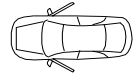

I Istruzioni di montaggio

F Instructions de montage

PL Instrukcja montażu

D Einbauanleitung

GB Fitting instructions

E Instrucciones de montaje

NL Inbouwhandleiding

SWE Montageanvisnin

KIT BS

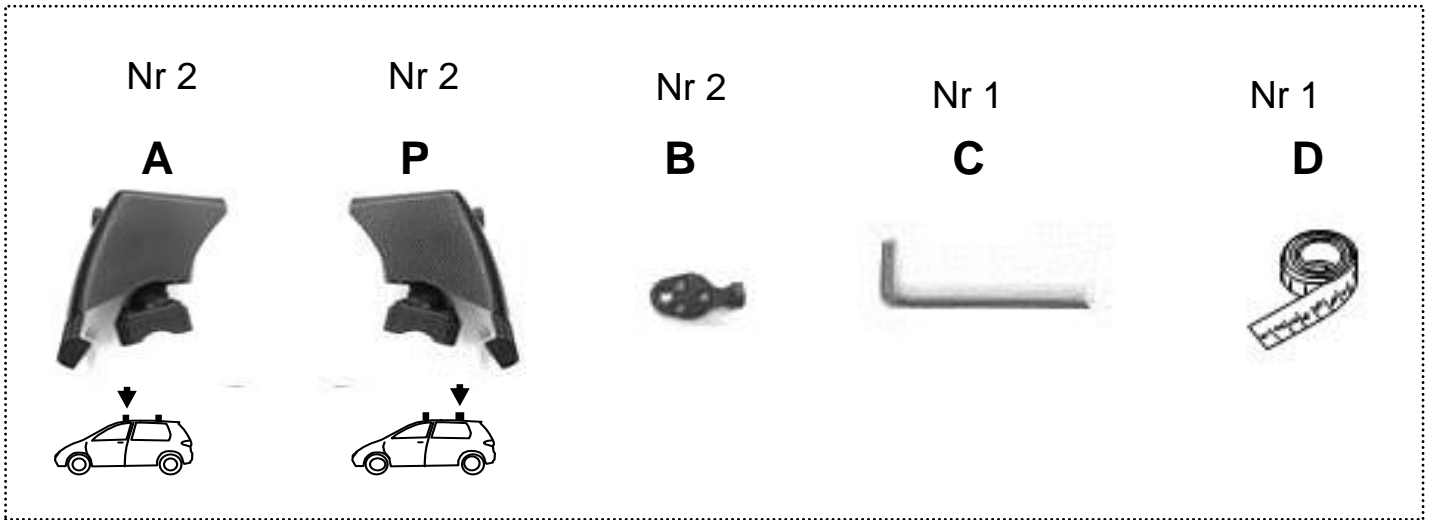

+

KIT ALU

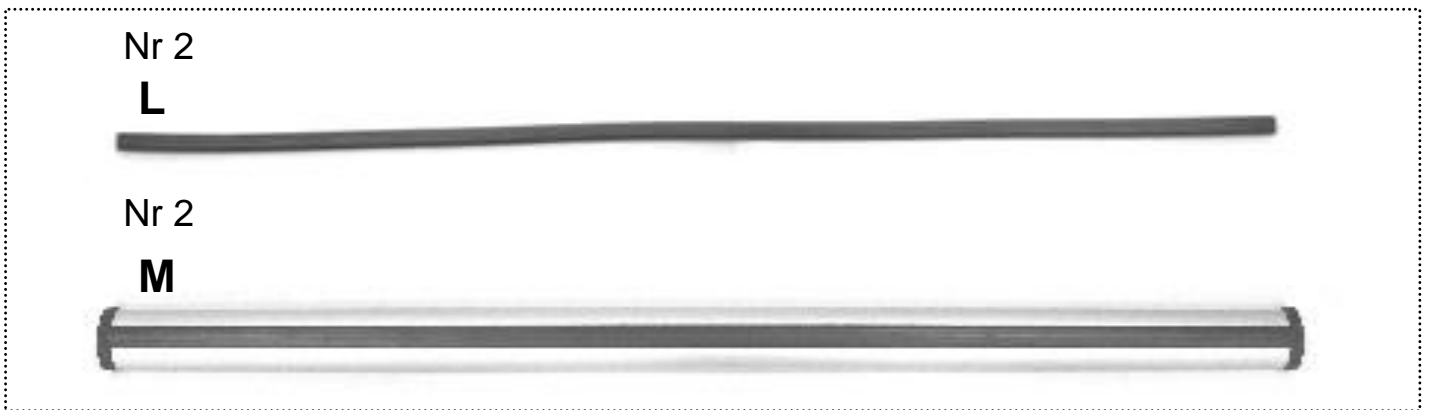

=

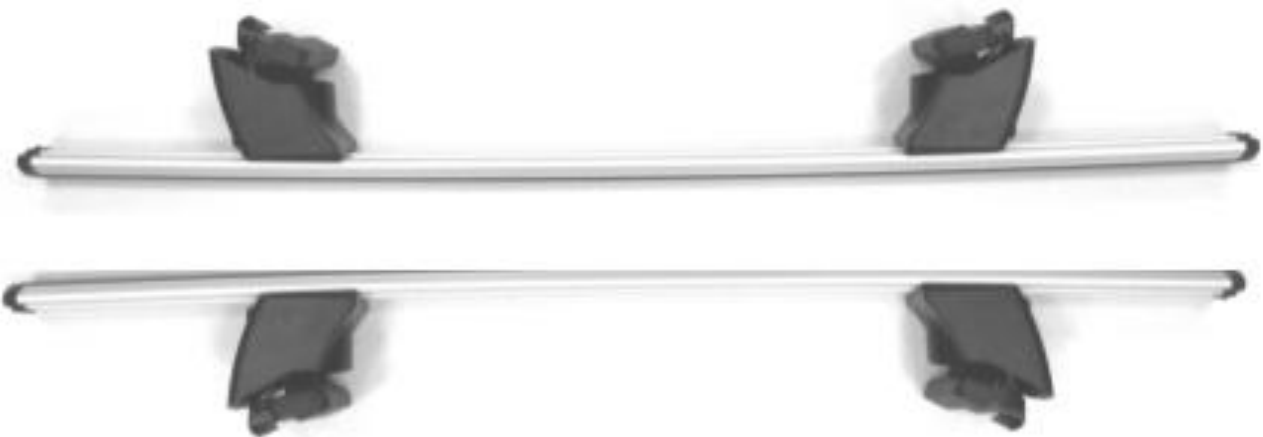

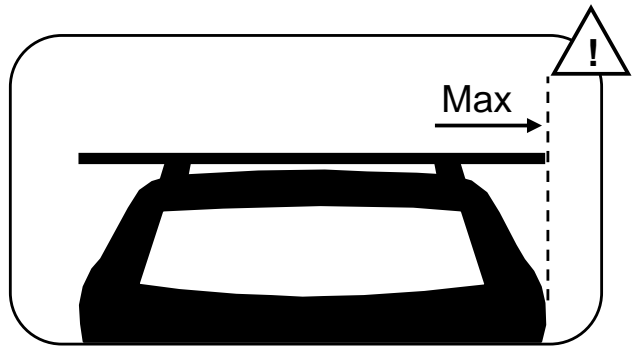
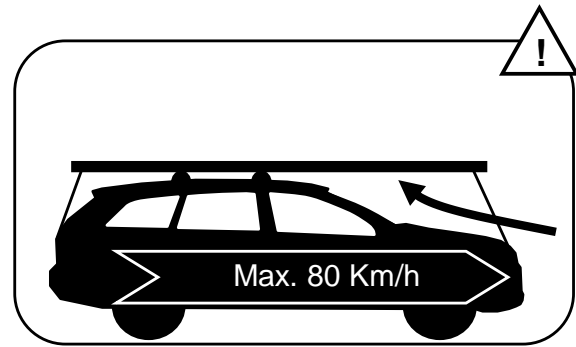
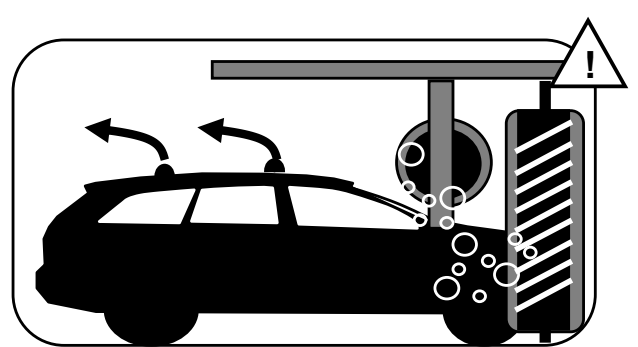
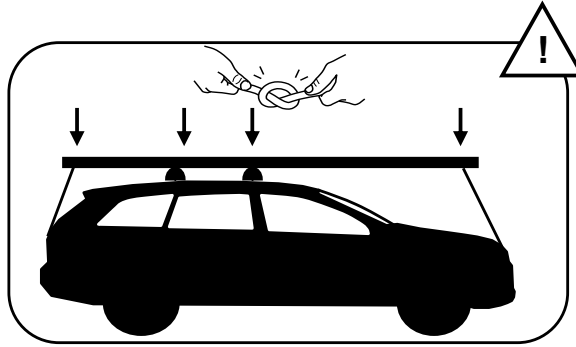
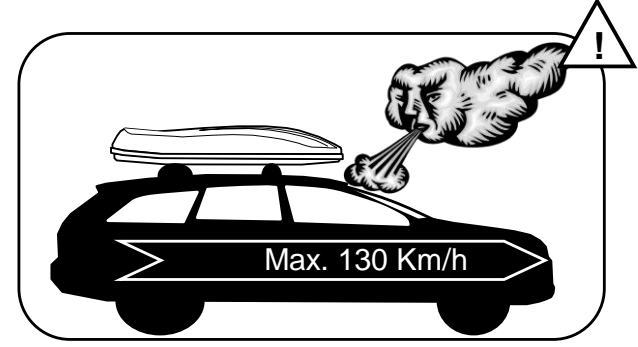
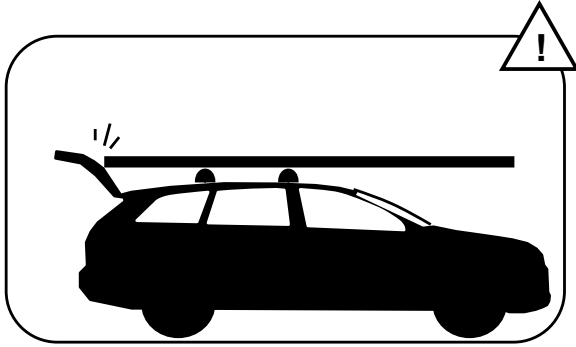
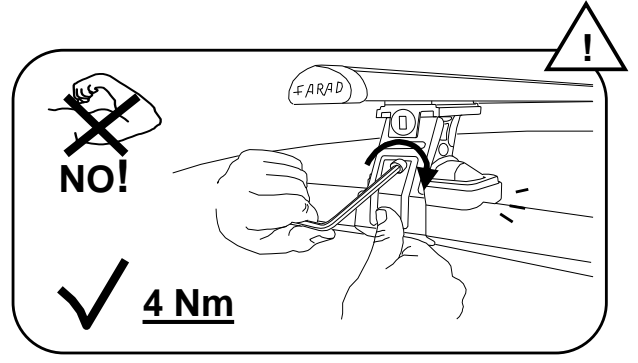
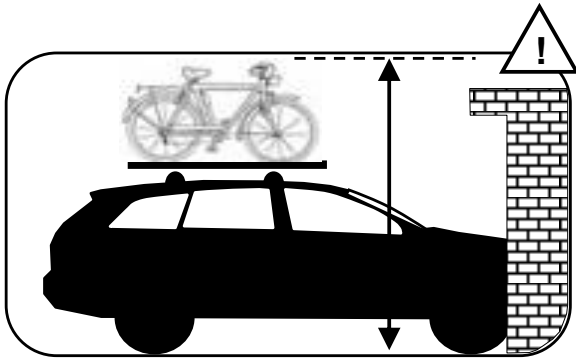

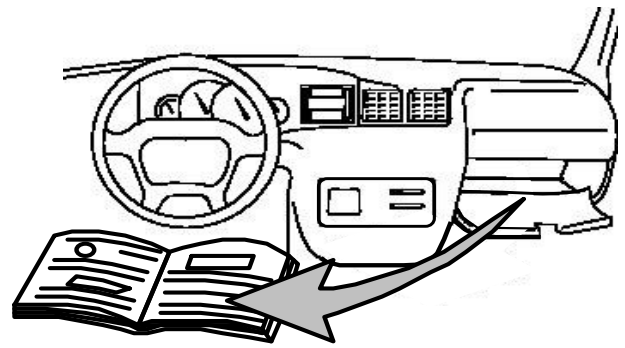
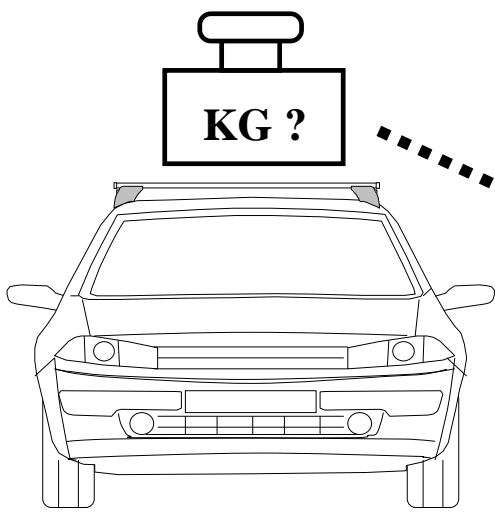

- I Controllare carico del tetto sul manuale dell'auto
- PL Sprawdź ładowność dachu w instrukcji
- GB Check roof load capacity in car instruction
- NL check de handleiding belasting van het dak van de auto
- F vérifier le chargement manuel du toit de la voiture
- D überprüfen Sie die manuelle Beladung der Autodach
- E comprobar la carga manual del techo del coche
- SWE kontrollera manuell inläggning på taket av bilen

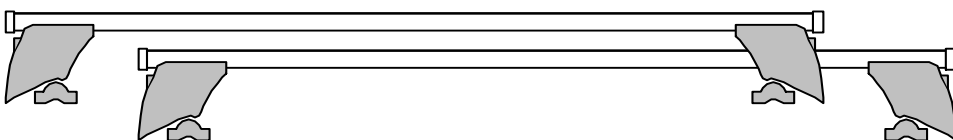
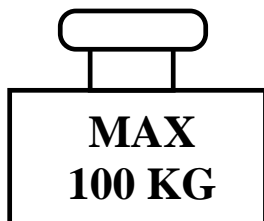
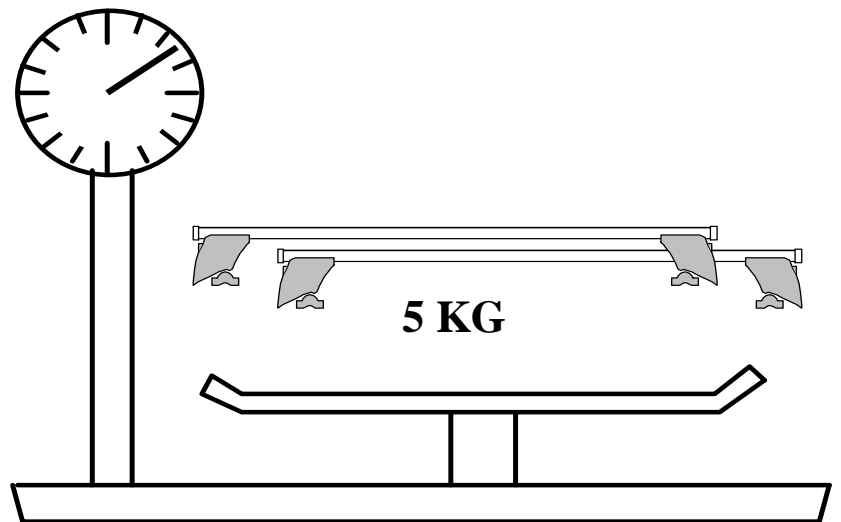

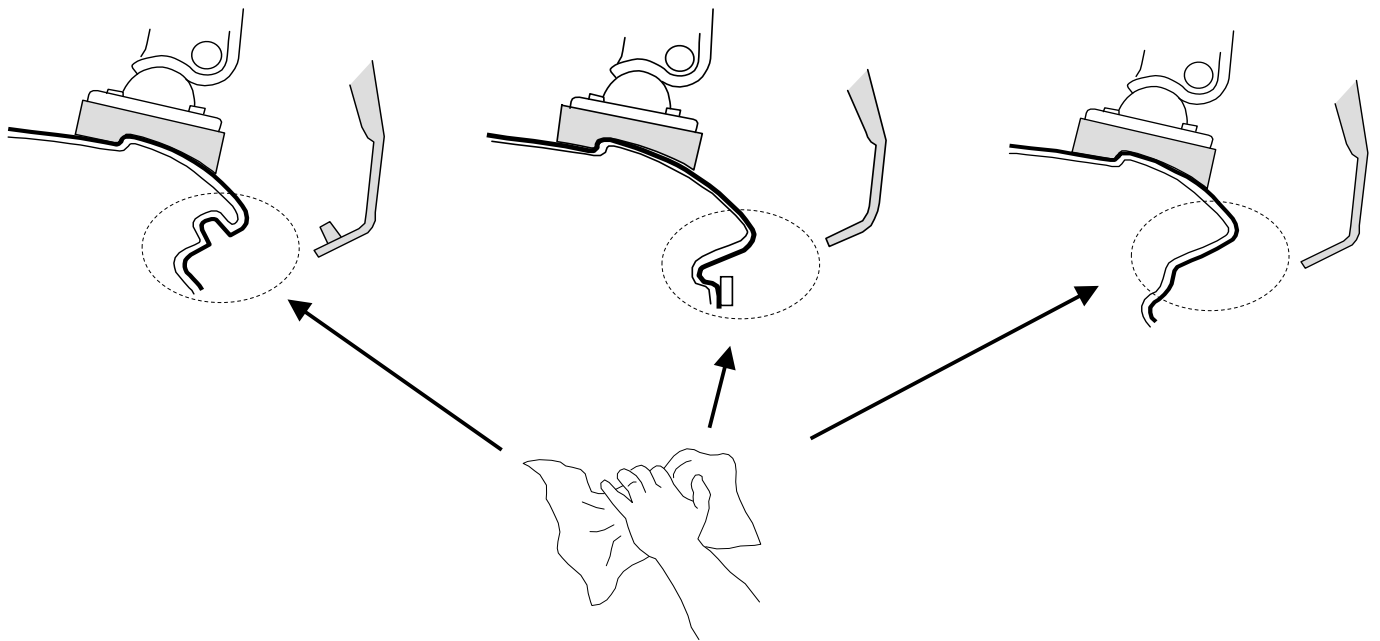
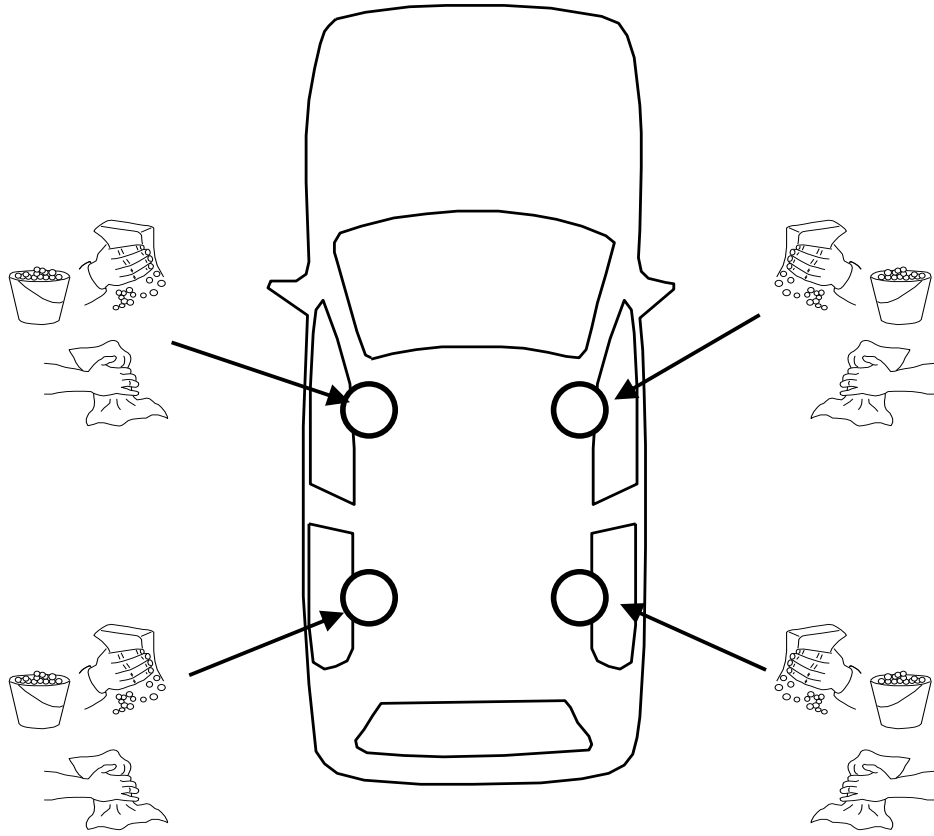

I **Montaggio Barra Anteriore**

F **Fixation Barre Avant**

PL **Montaż Bagażnika Bazowego Tylnego**

GB **Fitting Front Roof Bar**

D **Montage Vorderes Dachträgers**

NL **Montage Voorste Dakdrager**

SWE **Montering Av Främre Lasthållaren**

E **Fijación Barra Frontal**

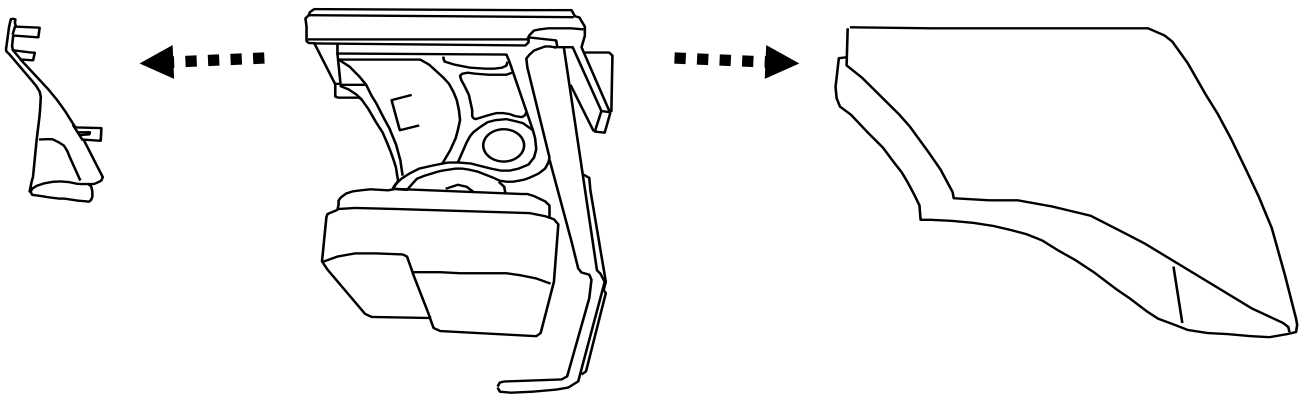
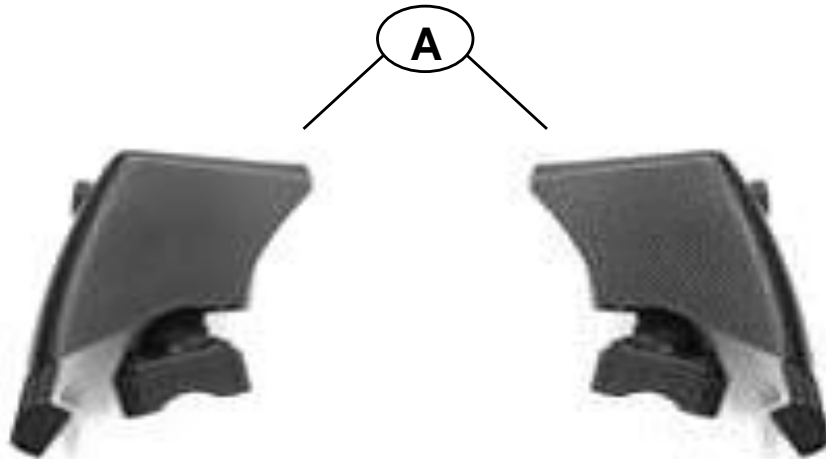
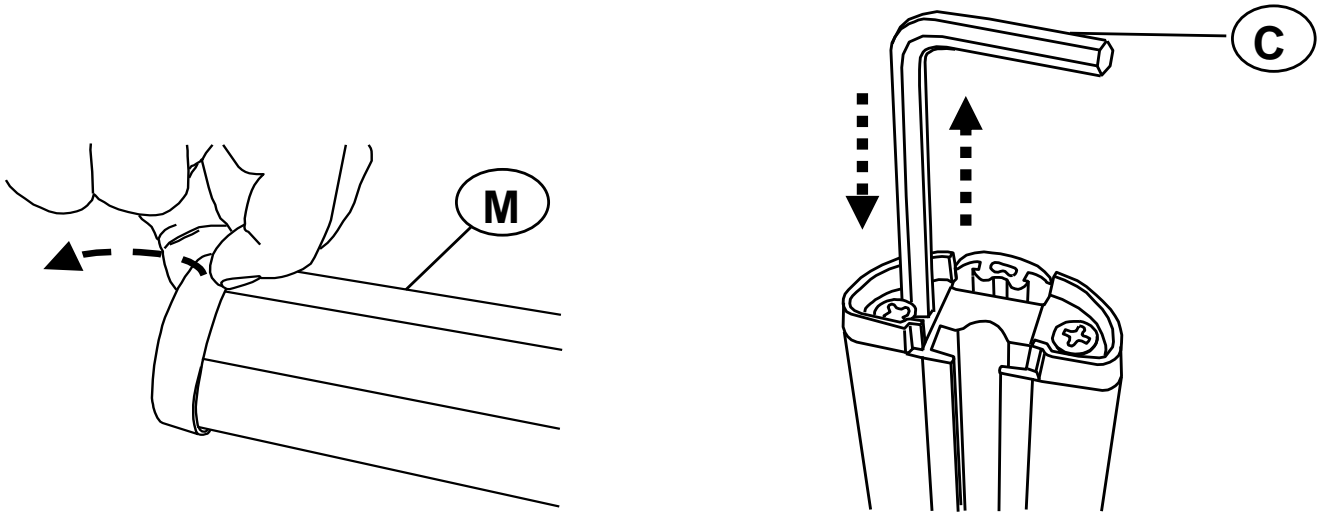

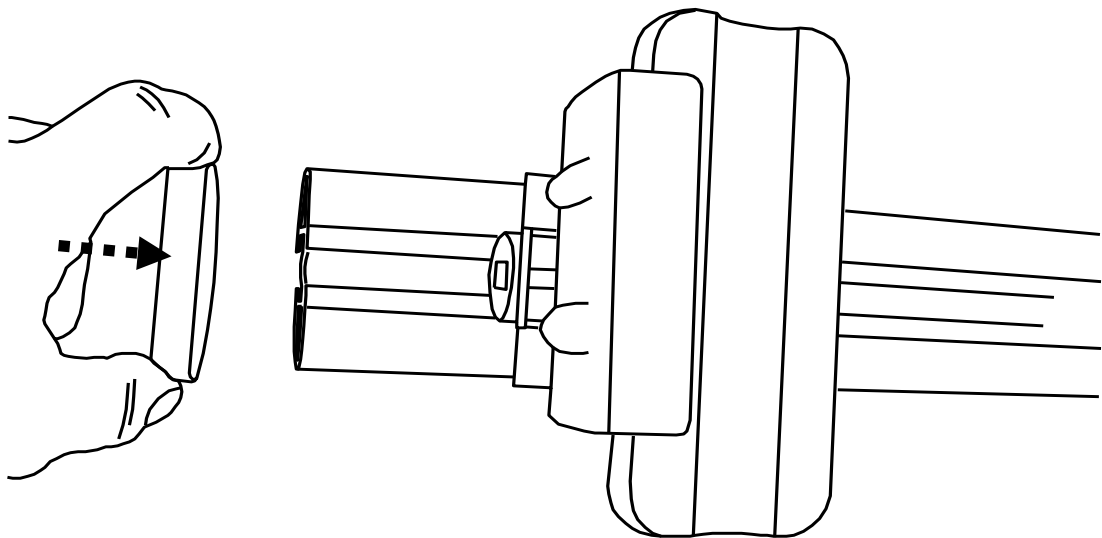
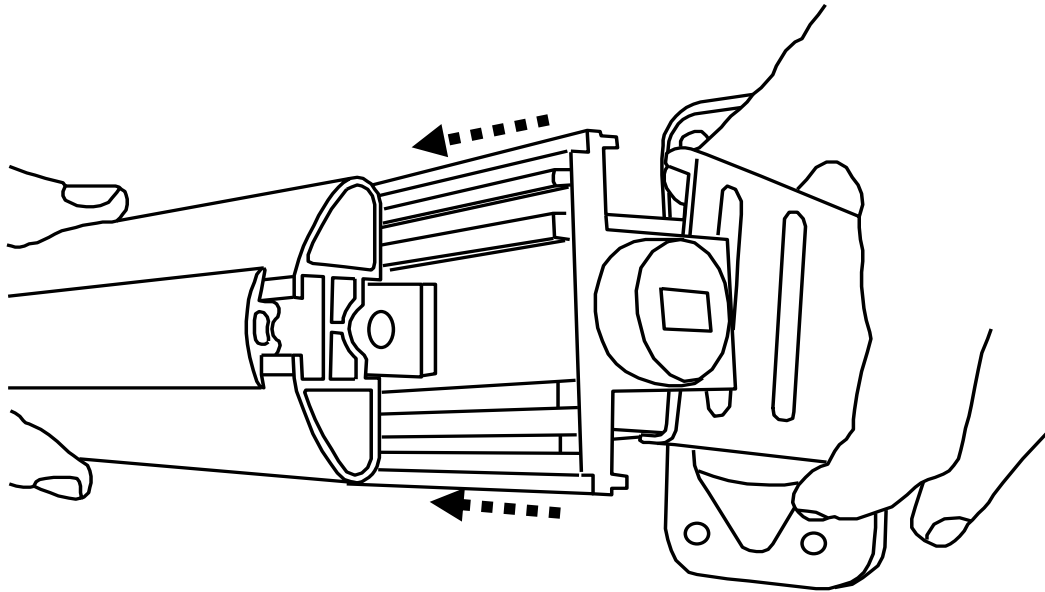
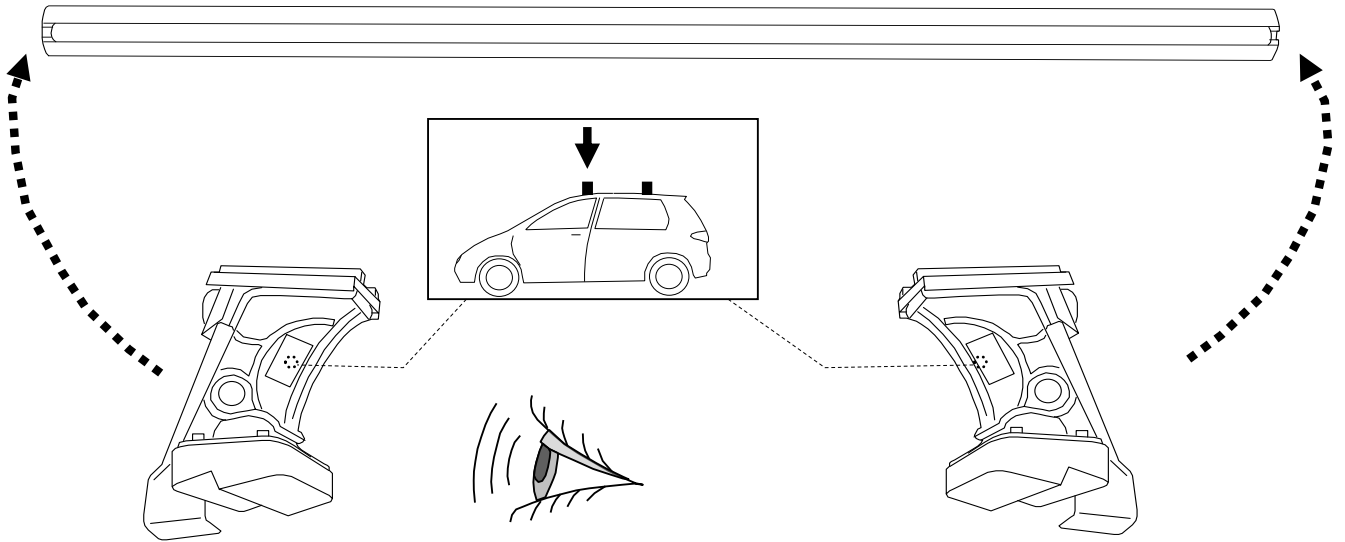

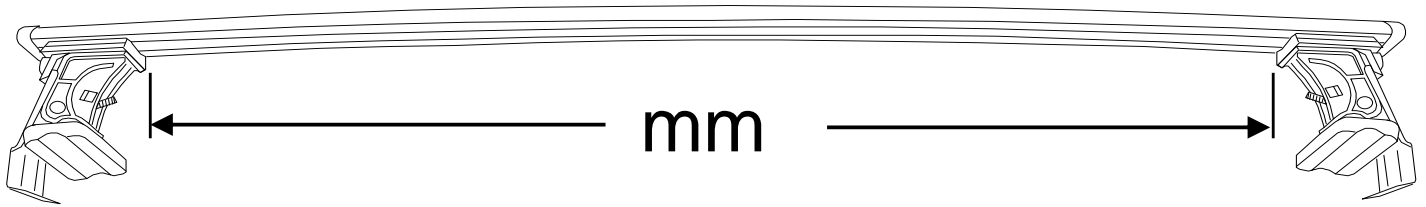

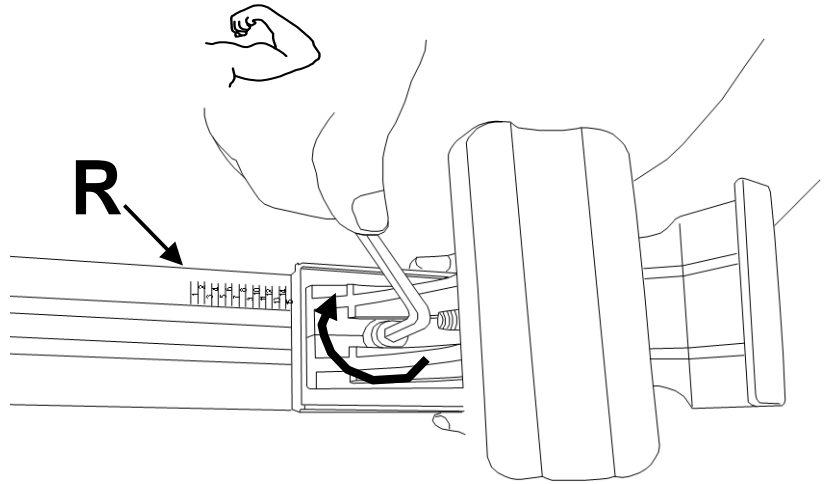
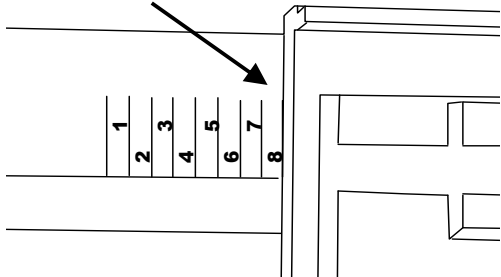

esempio - example

R= 8

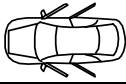
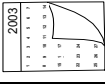

				R	mm
TOYOTA	IQ	3	2008 >	R= 31	1015

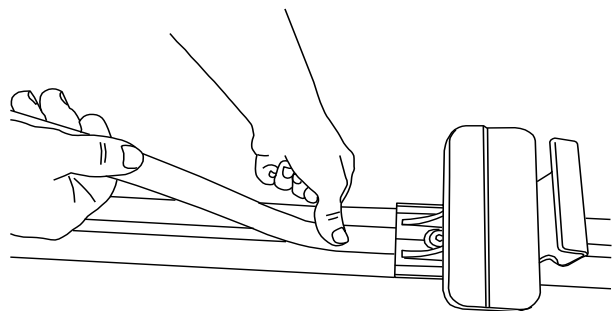
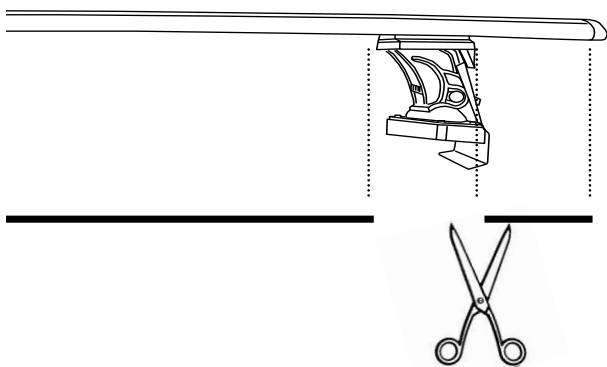

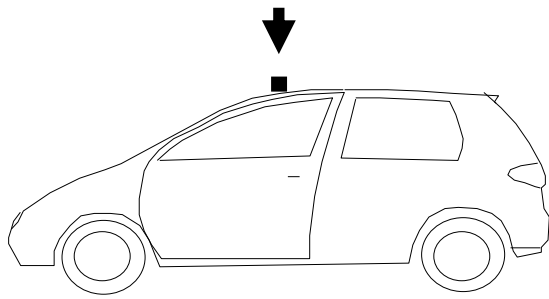

REV 000	10/05/2011	8 / 20
----------------	-------------------	---------------

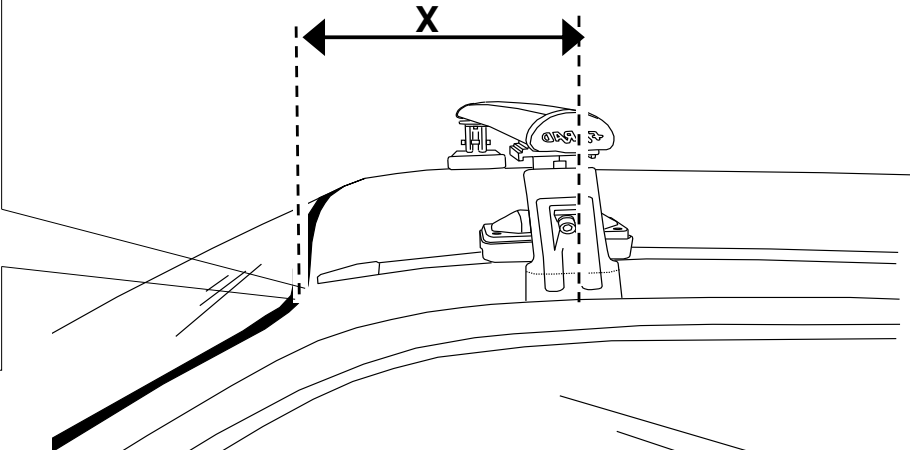
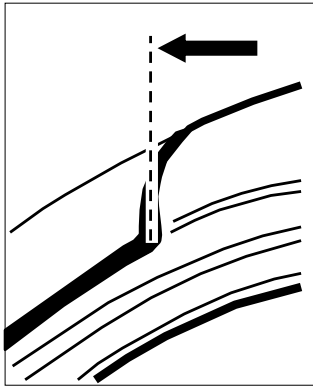

D

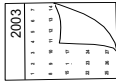

				X
TOYOTA	IQ	3	2008 >	X= 170

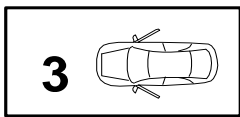

C



✓ **4 Nm**

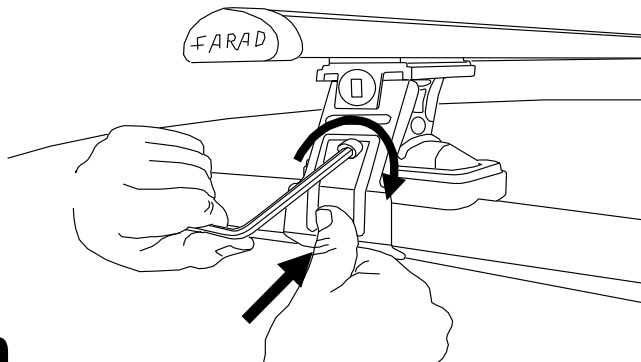

REV 000

10/05/2011

9 / 20

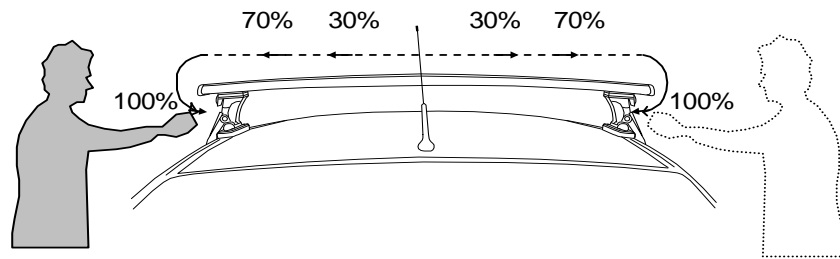

- | | | | |
|----|---|-----|------------------------------------|
| I | Alternare il fissaggio delle viti | F | Serrer alternativement chaque côté |
| PL | Śruby dokręcaj naprzemiennie | D | Die Schrauben abwechselnd anziehen |
| GB | Tighten alternately | E | Apretar alternativamente |
| NL | Afwisselend aan de linker- en de rechterkant aandraaien | SWE | Dra åt växelvis |

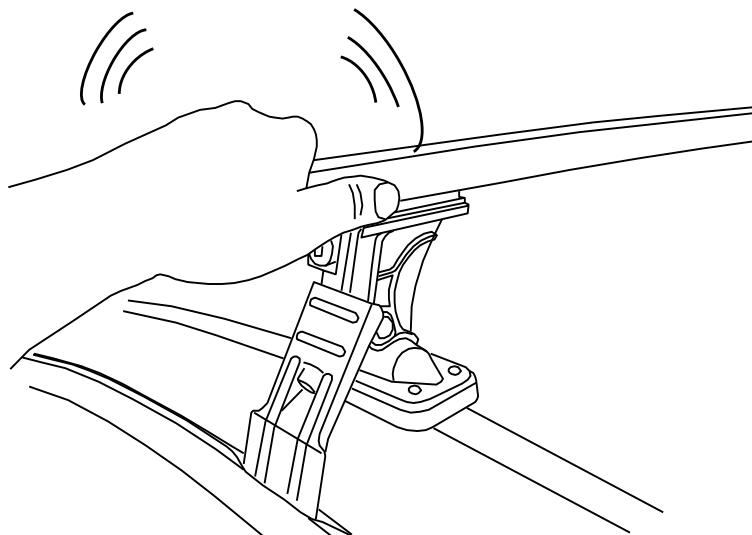
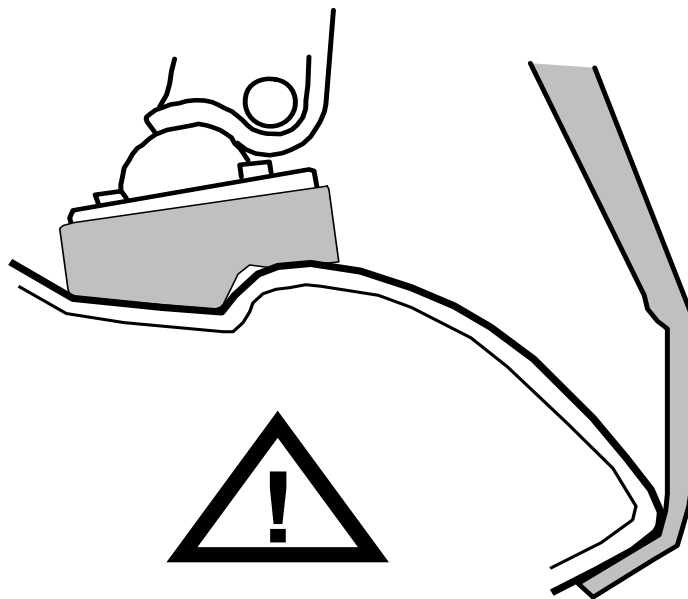
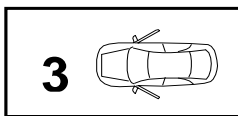

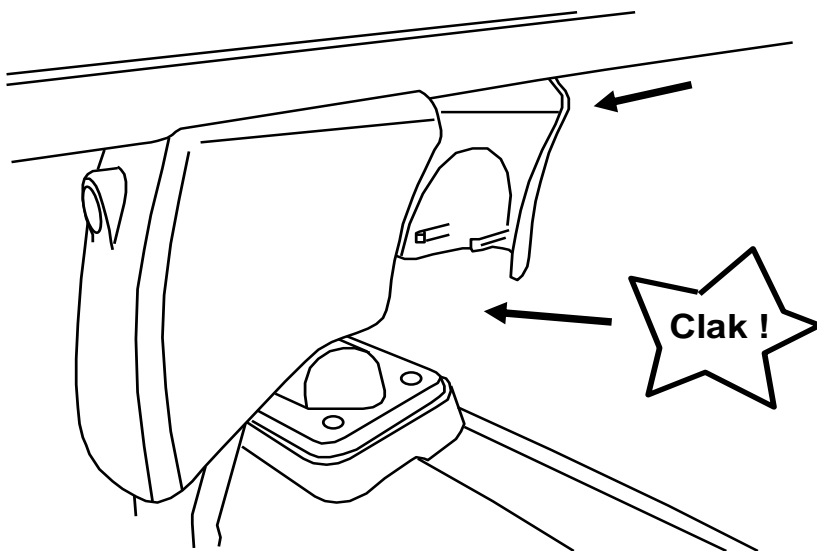
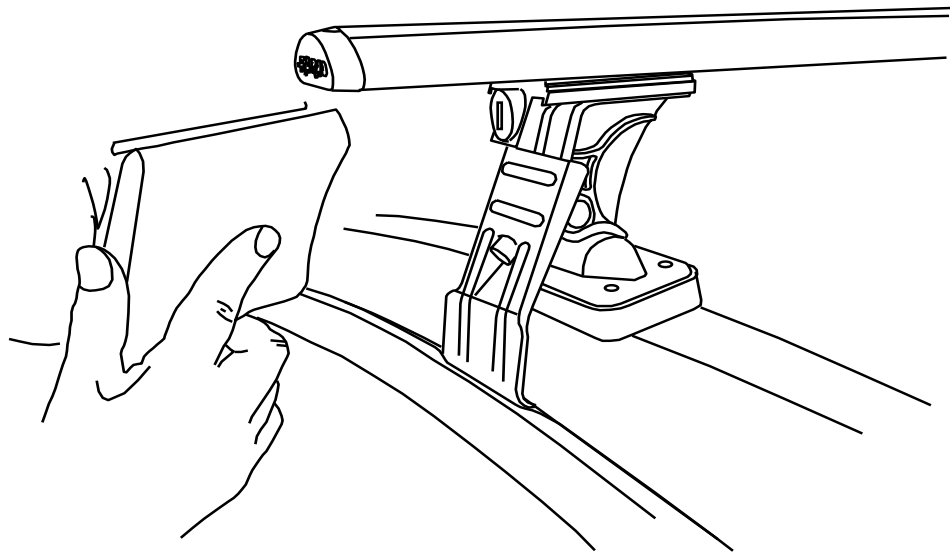

B

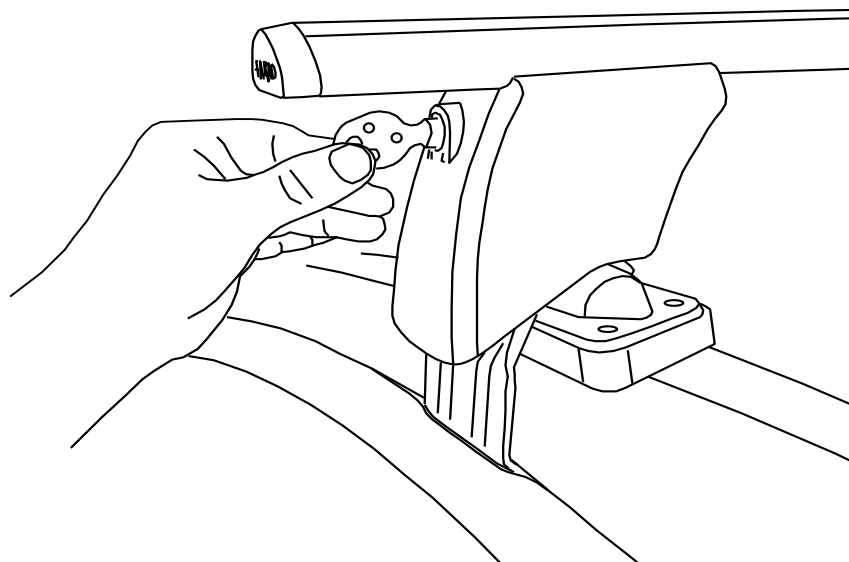

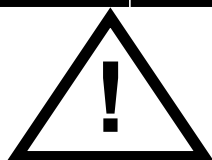
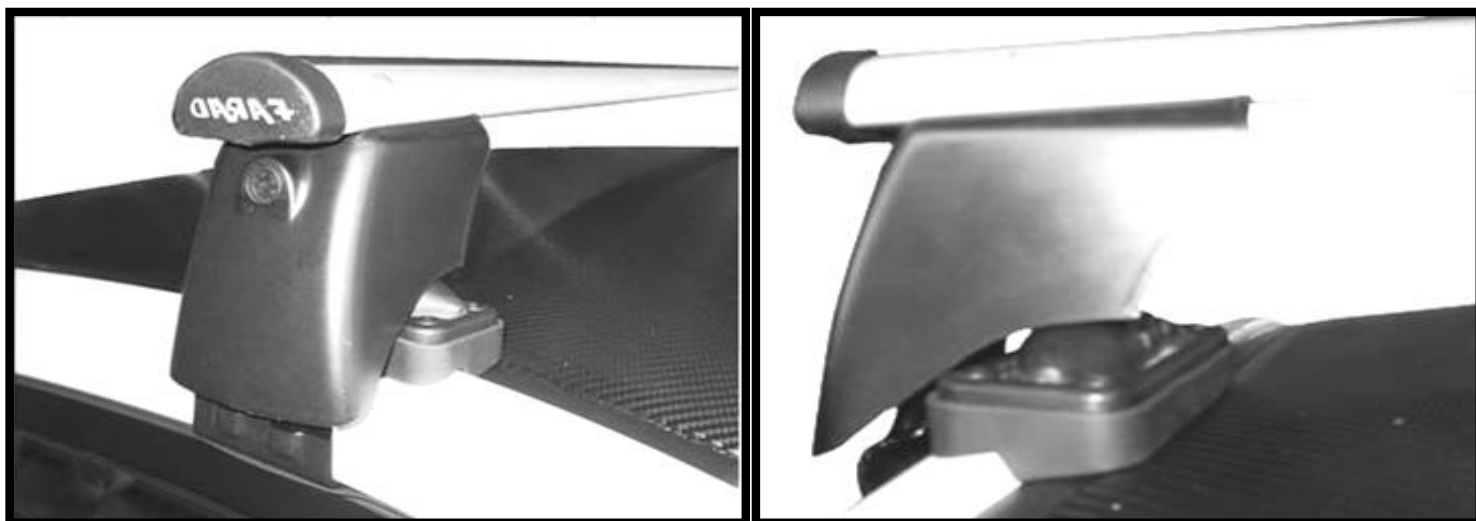
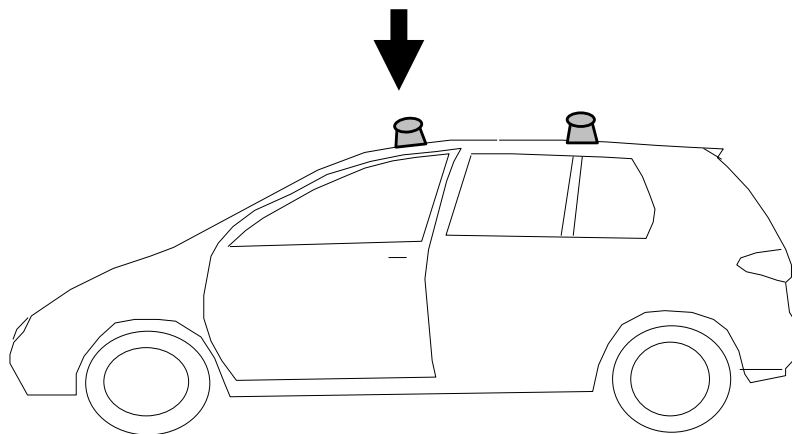

- I** CONTROLLARE PERIODICAMENTE IL FISSAGGIO DELLE VITI
- PL** OKRESOWO SPRAWDZAJ MOCOWANIE ŚRUB
- GB** CHECK THE SCREW FASTENING PERIODICALLY
- D** REGELMÄSSIG ÜBERPRÜFEN DIE BEFESTIGUNG DER SCHRAUBEN
- SWE** REGELBUNDET KONTROLLERA OM FASTSTÄLLANDE AV SKRUVARNA
- F** VERIFIEZ LA FIXATION DES VIS PERIODIQUEMENT

I **Montaggio barra posteriore**

PL **Montaż Bagażnika Bazowego Przedniego**

SWE **Montering Främre Lasthållaren**

NL **Montage Achterste Dakdrager**

F **Fixation Barre Arriere**

GB **Fitting Rear Roof Bar**

E **Fijación Barra Trasera**

D **Montage Heckdachträgers**

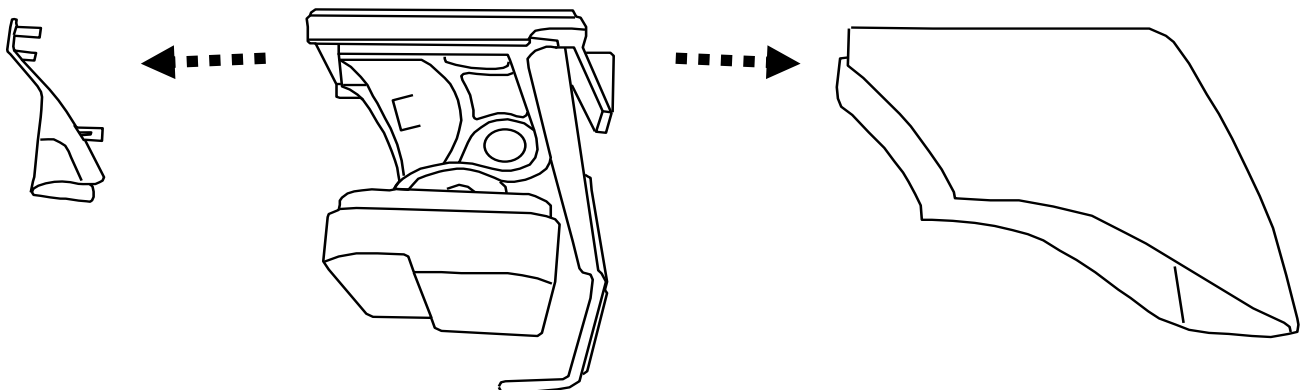
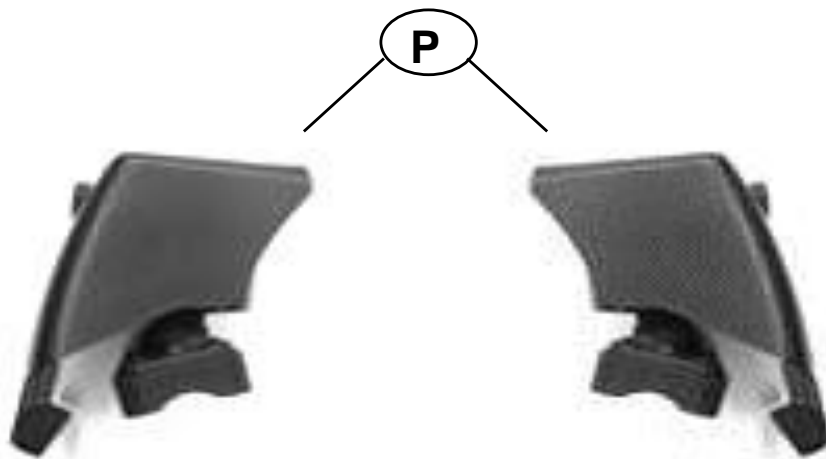
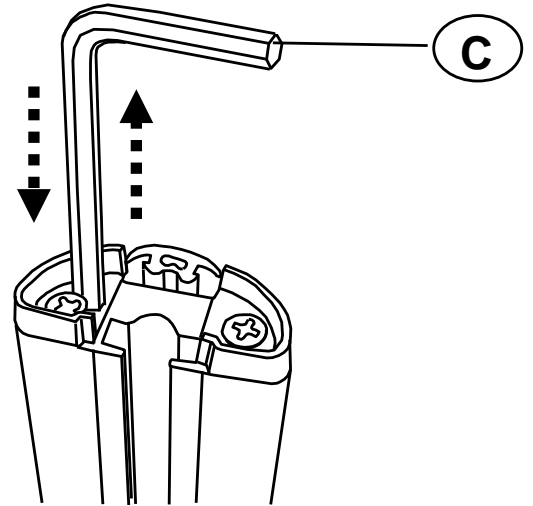
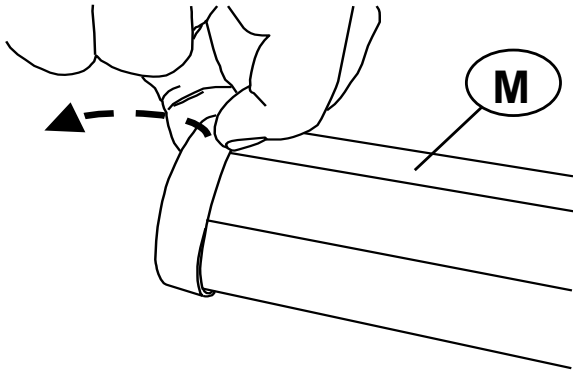

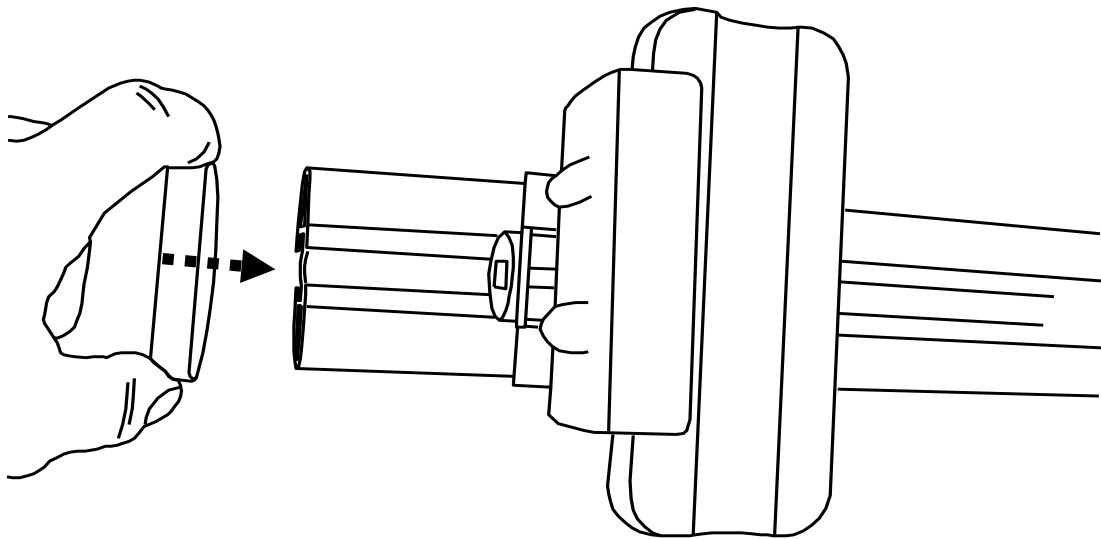
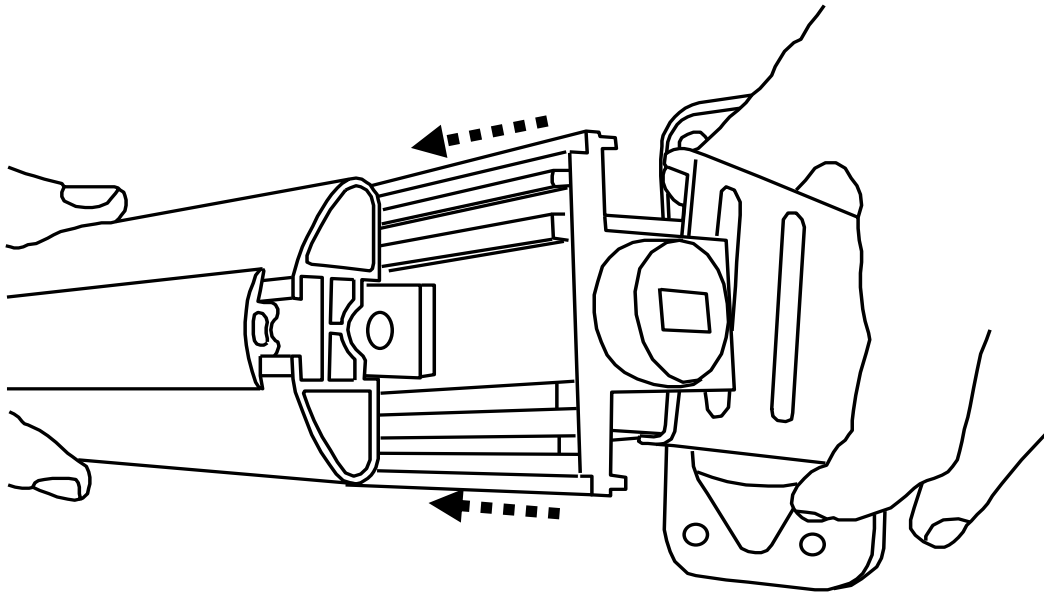
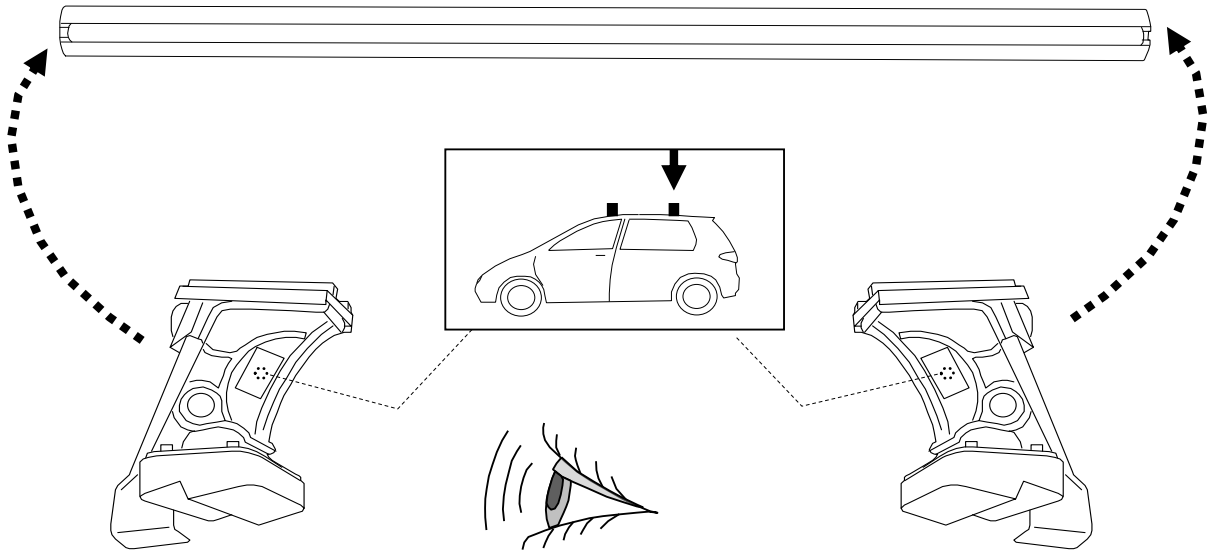

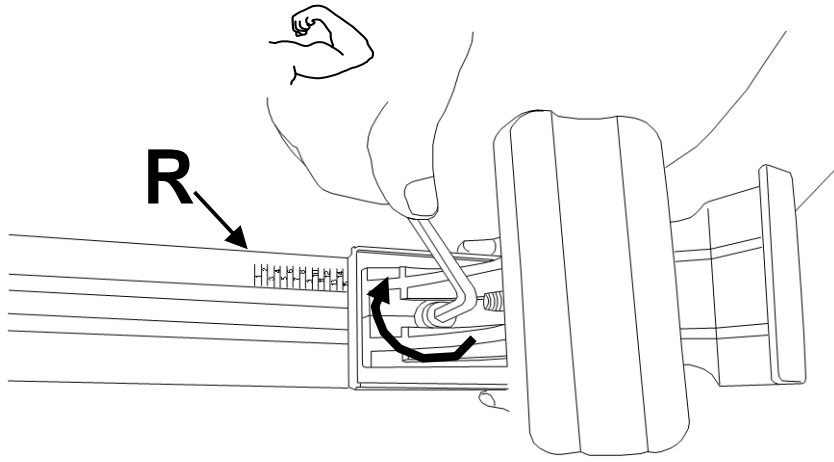
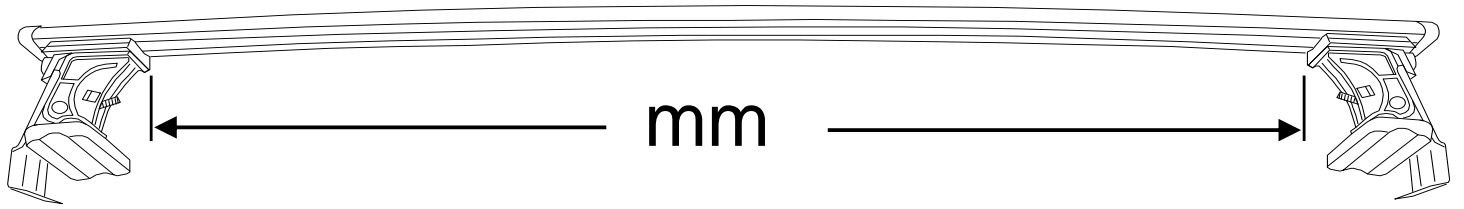

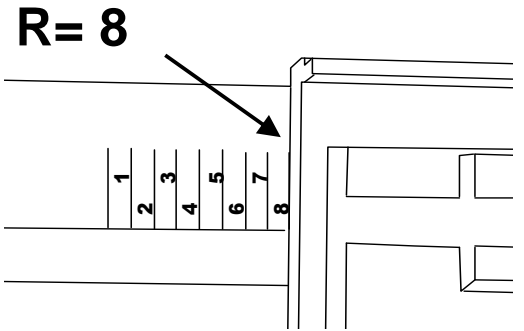

esempio - example

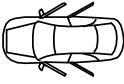

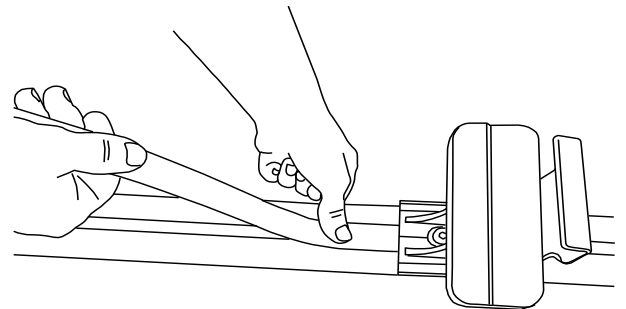
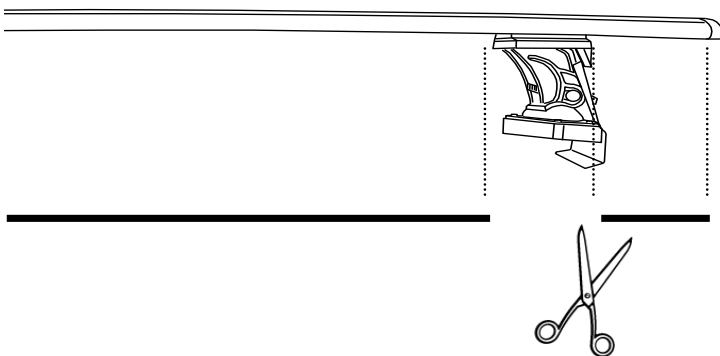

			R	mm
TOYOTA	IQ	3	R= 20	965

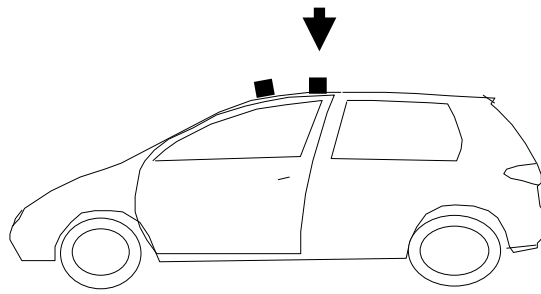

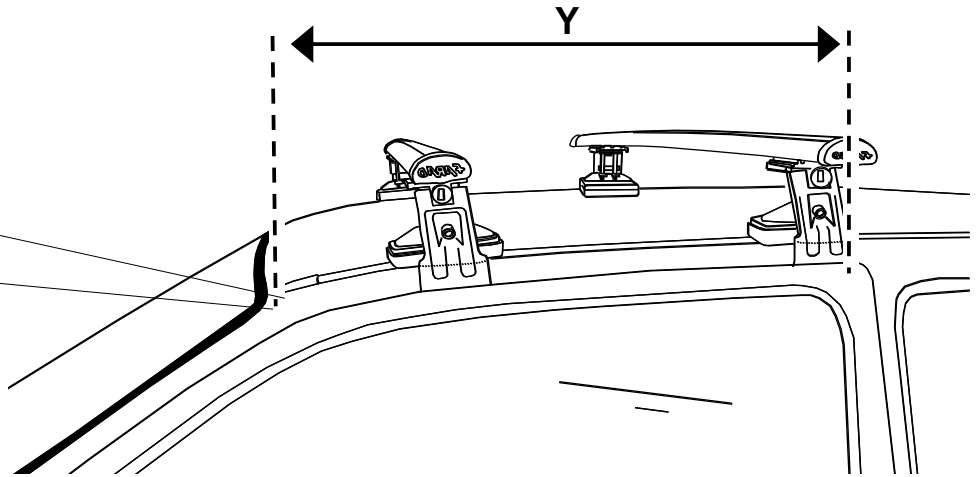
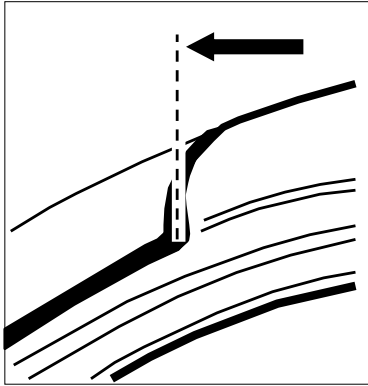

D

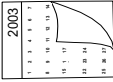

			Y
TOYOTA	IQ	2008 >	Y= 630

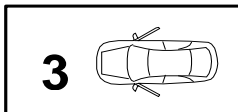

C



✓ **4 Nm**

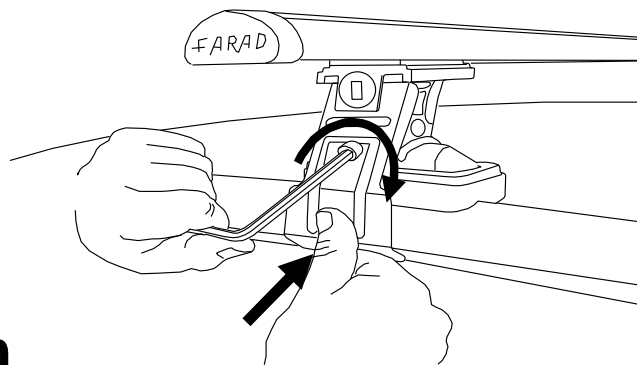

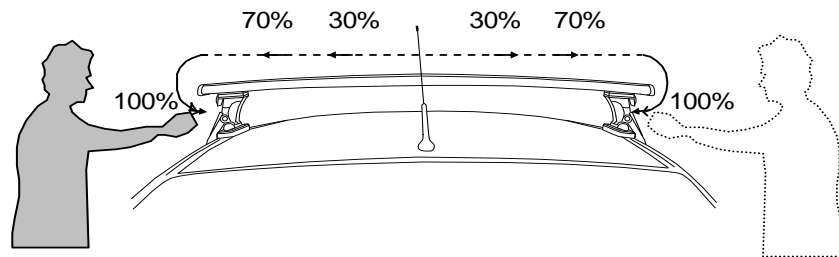

I Alternare il fissaggio delle viti
PL Śruby dokręcaj naprzemiennie
GB Tighten alternately
NL Afwisselend aan de linker- en de rechterkant aandraaien

F Serrer alternativement chaque côté
D Die Schrauben abwechselnd anziehen
E Apretar alternativamente
SWE Dra åt växelvis

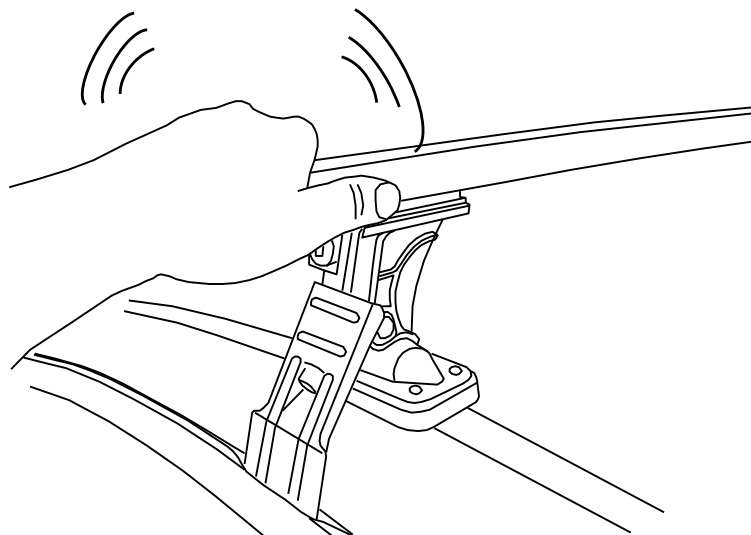
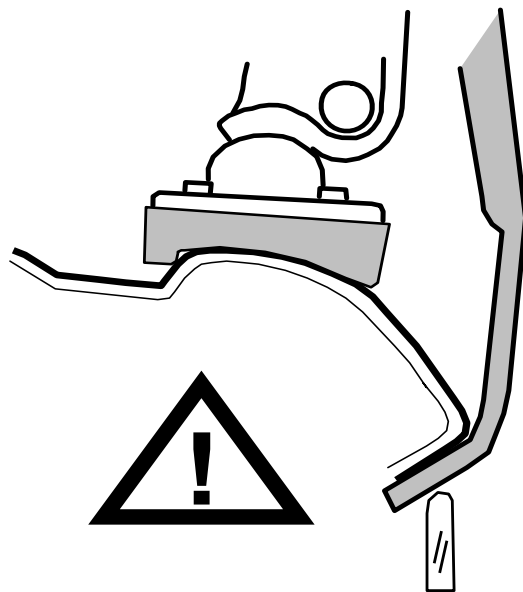
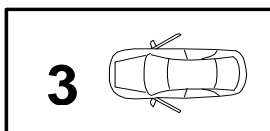

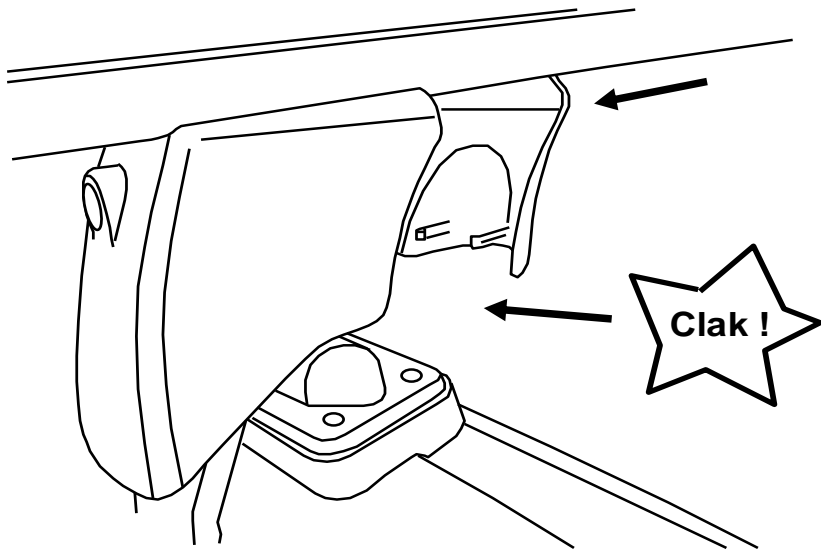
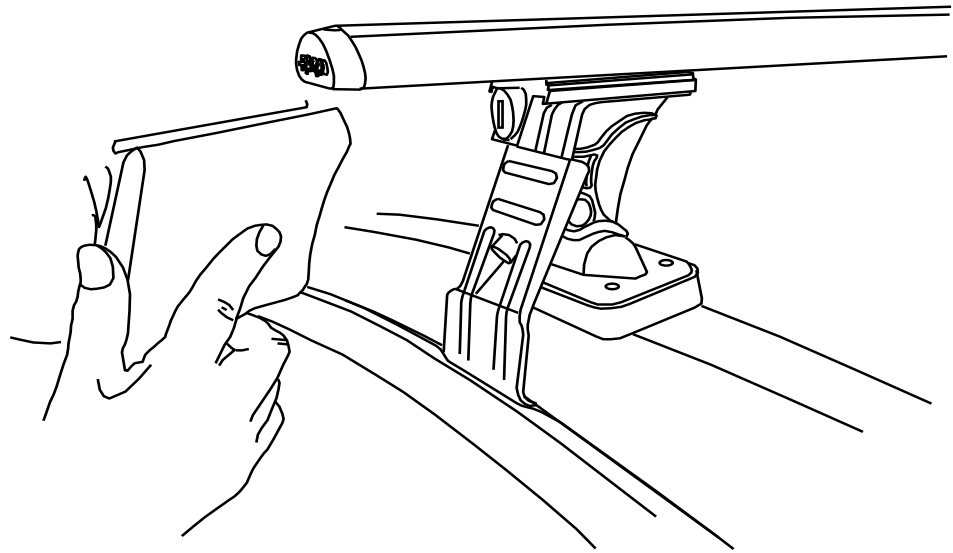

B

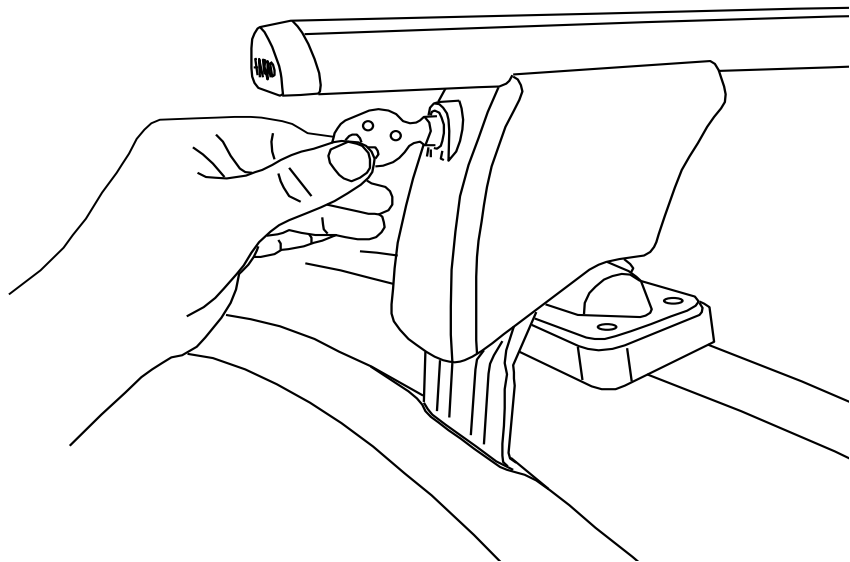

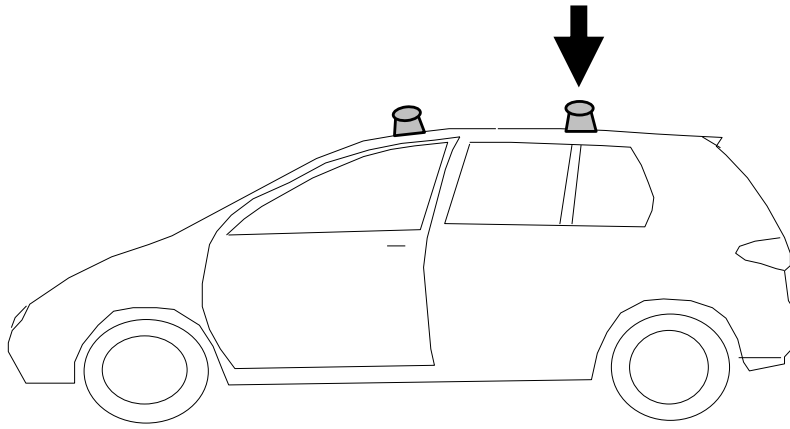

- I** CONTROLLARE PERIODICAMENTE IL FISSAGGIO DELLE VITI
- PL** OKRESOWO SPRAWDZAJ MOCOWANIE ŚRUB
- GB** CHECK THE SCREW FASTENING PERIODICALLY
- D** REGELMÄSSIG ÜBERPRÜFEN DIE BEFESTIGUNG DER SCHRAUBEN
- SWE** REGELBUNDET KONTROLLERA OM FASTSTÄLLANDE AV SKRUVARNA
- F** VERIFIEZ LA FIXATION DES VIS PERIODIQUEMENT

RICAMBI - SPARE PARTS



PIEDE GIREVOLE
90341 / 2



PIEDE FISSO
90341 / 15



SUPPORTO CENTRALE
90341 / 1

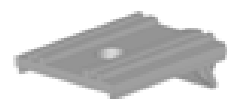

SUPPORTO BARRA
90341 / 5



SOTTO PIEDE SP01
90341 / 3



SOTTO PIEDE SP08
90341 / 14



SOTTO PIEDE SP12
90341 / 1



SOTTO PIEDE SP07
90341 / 11



SOTTO PIEDE SP 10
90341 / 12



SOTTO PIEDE SP04
90341 / 13

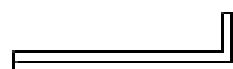

CHIAVE ESAGONALE 6
9331 / 148



PIASTRINA
90341 / 21



DISTANZIALE
90341 / 20



NOTTOLINO + n° comb
90341 / 6



SOTTO TAPPO
90241 / 9



TAPPO BARRA
90241 / 6



INVOLUCRO POST.
90341 / 9



INVOLUCRO ANTERIORE
90341 / 8



CHIAVE + n° comb
90341 / 7



PALETTA
90341 / 4



BARRA ALLUMINIO
90241 / 7



GUARNIZIONE BARRA
90241 / 8



RIGA CARTA
90341 / 19



PERNO
90241 / 15

FARAD

tel. 011 9710900 - fax. 011 9710947
www.farad.it

REV 000

10/05/2011

20 / 20