

# Opt.Exclusiv Minibox

Art. 6201972

cm 120X68X68 300 lt

Ⓡ Istruzioni per l'uso per	Ⓡ Mode d'emploi	Ⓡ Instrucciones
Ⓡ Bedienungsanleitung	Ⓡ Instructions	Ⓡ Instrukcja instalacji

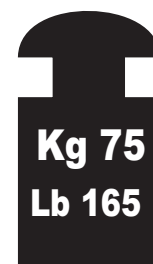

Ⓡ Componenti	Ⓡ Composants	Ⓡ Componentes
Ⓡ Komponenten	Ⓡ Parts	Ⓡ Składniki

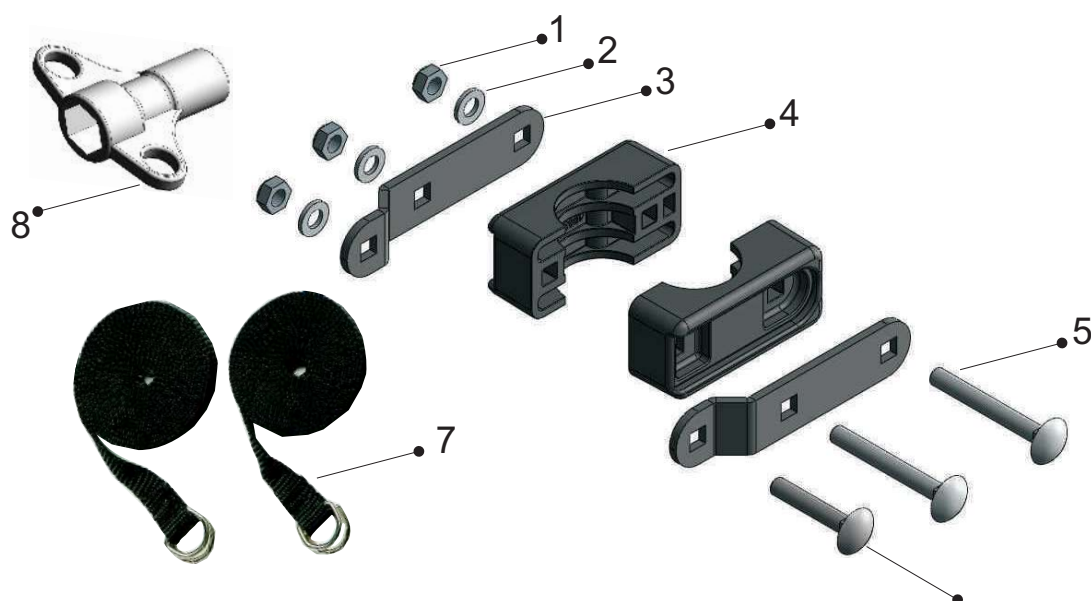



1	3052615	x 6
2	3043476	x 6
3	3015301	x 4
4	4083883	x 4
5	3049568	x 4
6	3049564	x 2
7	4078785	x 2
8	3050611	x 1

(D) **Wichtige Hinweise**  
(F) **Attention**

(GB) **Warning**

(I) **Avvertenze**  
(E) **Advertencias**

(D)   
**Bewahren Sie die Betriebsanleitung sorgfältig auf und geben Sie diese allenfalls an Nachbenutzer weiter.**  
**Achtung:** Der Fahrzeugführer ist für eine korrekte Montage und deren Unterhalt sowie aller am Auto befindlichen Ausrüstungsgegenstände verantwortlich und haftbar.

(F)   
**Veillez conserver soigneusement ce mode d'emploi et le remettre à tout nouvel utilisateur du porte vélos arrière.**  
**Important:** le conducteur du véhicule est responsable légalement, en cas d'accident, de la fixation correcte et sûre et du bon entretien de tous les accessoires ajoutés à la carrosserie.

(GB)   
**Keep these use instructions in a safe place and attach them to the bike rack if another person has to use it.**  
**Warning:** the driver of the car is responsible for the correct fitting and regular maintenance of all the car accessories, even in the event of an accident.

(I)   
**Conservare queste istruzioni per l'uso in un luogo sicuro e allegarle al portabiciclette qualora un'altra persona dovesse utilizzarlo.**  
**Avvertenza:** il conducente dell'autovettura è responsabile, anche in caso di incidente, del corretto montaggio e della regolare manutenzione di tutti gli accessori dell'auto.

(E)   
**Conservar estas instrucciones de uso en un lugar seguro y adjuntarlas al porta-bicicletas, en el caso que otra persona tenga que utilizarlo.**  
**Advertencia:** El conductor del coche es responsable además, en caso de accidente, de la correcta instalación y del mantenimiento regular de todas los accesorios del coche.

(D) **GARANTIE DER NUTZUNG**

Wir übernehmen keine Verantwortung für den Fall, dass die Anweisungen bei der Montage und Verwendung des Produkts nicht beachtet werden. Mögliche Entschädigungsansprüche können nur durch Vorlage der Rechnung und eine detaillierte Fotodokumentation der korrekten Montage des Produkts, in der die Identifizierung des Fahrzeugs und des Produkts eindeutig ist, erfolgen.

(F) **GARANTIE D'UTILISATION**

Nous déclinons toute responsabilité en cas de non-respect des instructions d'assemblage et d'utilisation du produit.  
Les éventuels droits à la compensation ne peuvent avoir lieu que par la présentation du reçu d'achat et d' une documentation photographique détaillée de l'assemblage correct du produit, dans lesquels sont évidents et sans

(GB) **WARRANTY OF USE**

We decline all responsibility in case of failure to apply the instructions during assembly & use of the product.  
Any rights to compensation can only occur by presenting cash receipts & a detailed photographic documentation of the correct assembly of the product in which the product & vehicle identification is unequivocal.

(I) **GARANZIA DI UTILIZZO**

Si declina ogni responsabilità in caso di mancata applicazione delle istruzioni nel montaggio e nell'utilizzo del prodotto.  
Eventuali diritti al risarcimento possono subentrare solo presentando gli scontrini di cassa ed una dettagliata documentazione fotografica del corretto montaggio del prodotto in cui risultino inequivocabili l'identificazione dello stesso e della vettura.

(ES) **GARANTÍA DEL USUARIO**

Declinamos toda responsabilidad en caso de no aplicar las instrucciones en el montaje y uso del producto.  
Los posibles derechos de compensación solo pueden tener lugar presentando las cajas registradoras y una documentación fotográfica detallada del correcto montaje del producto en el que la identificación de los mismos y el automóvil es inequívoca.

**1 Open**

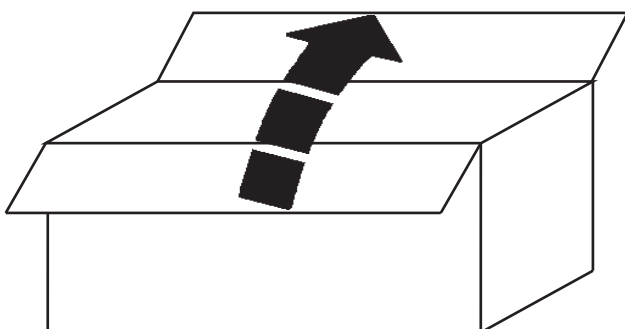

**2 Plastic Protection**



3



4



5

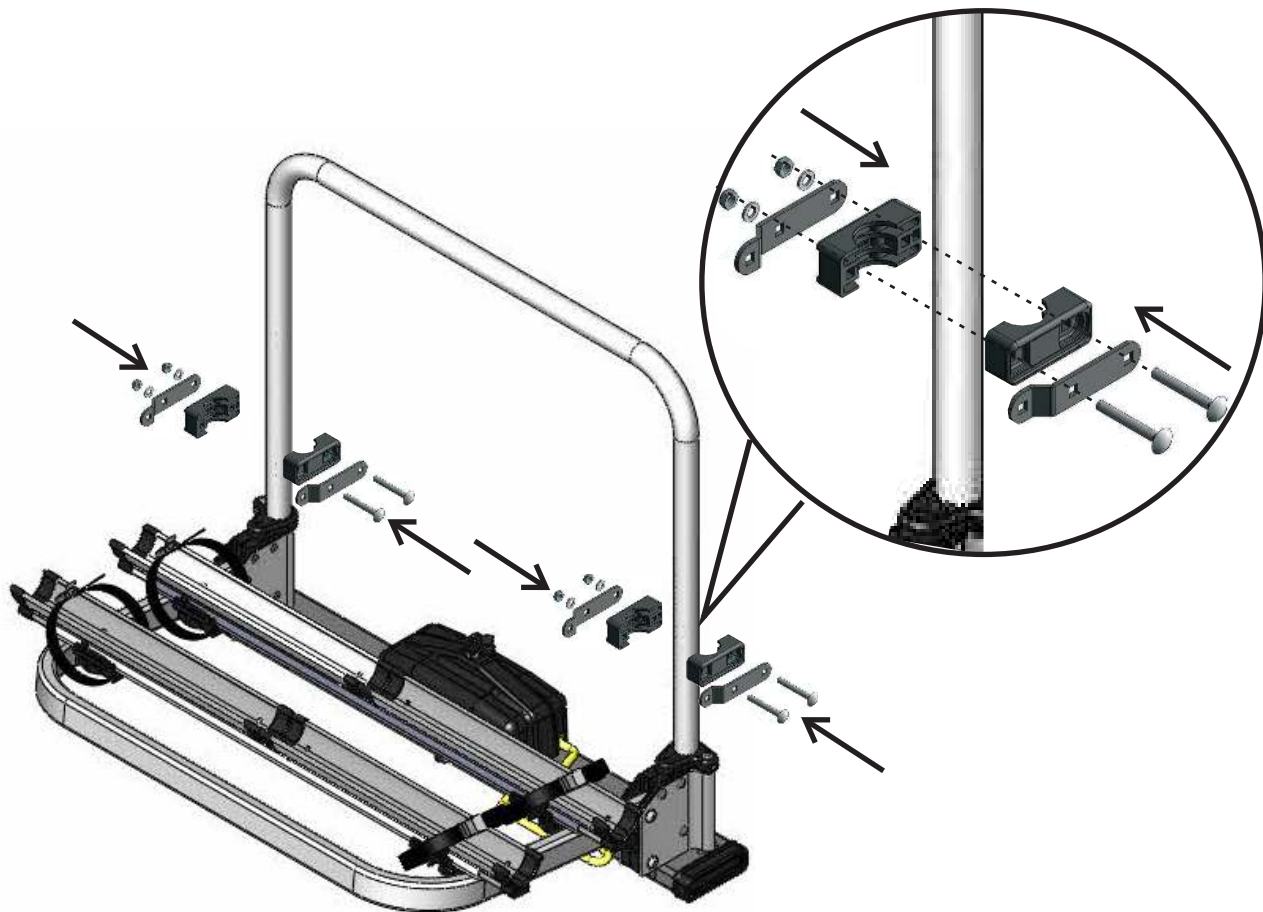

6

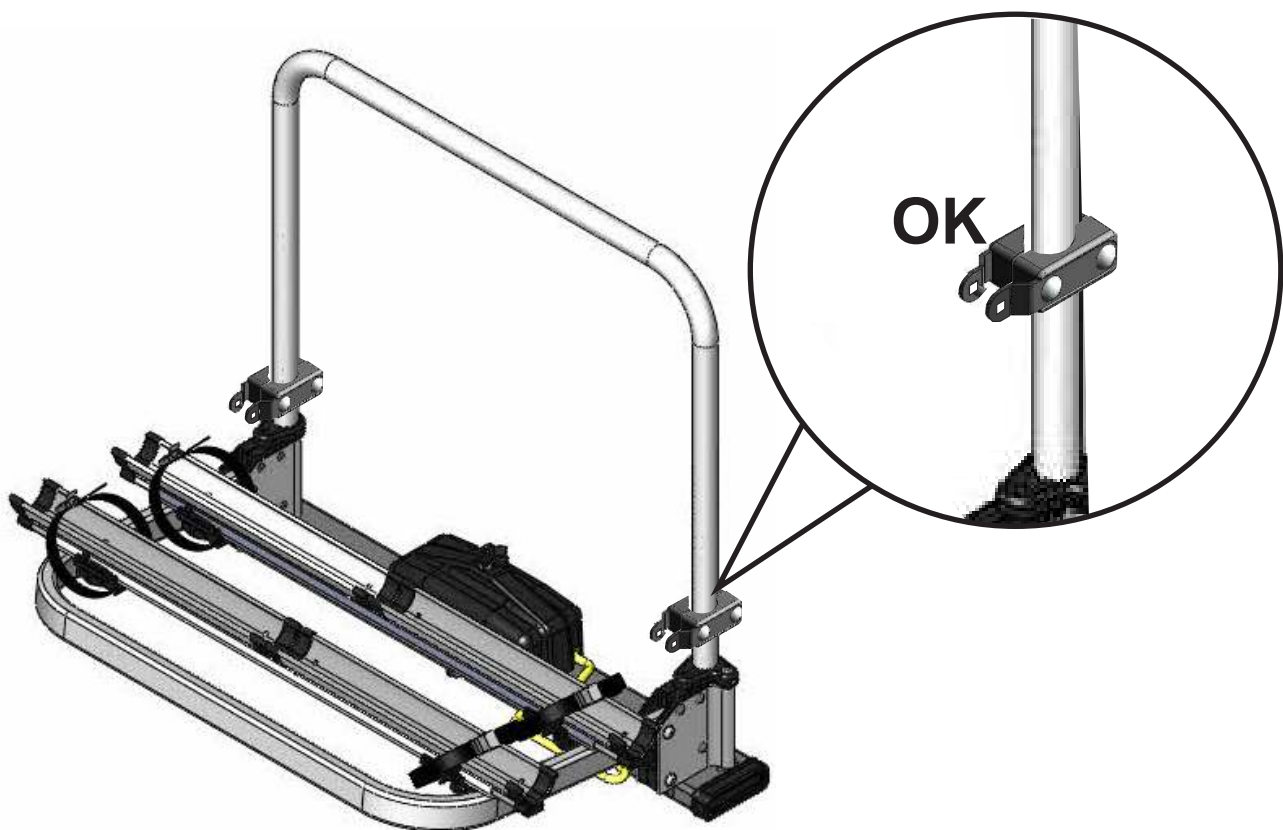

7

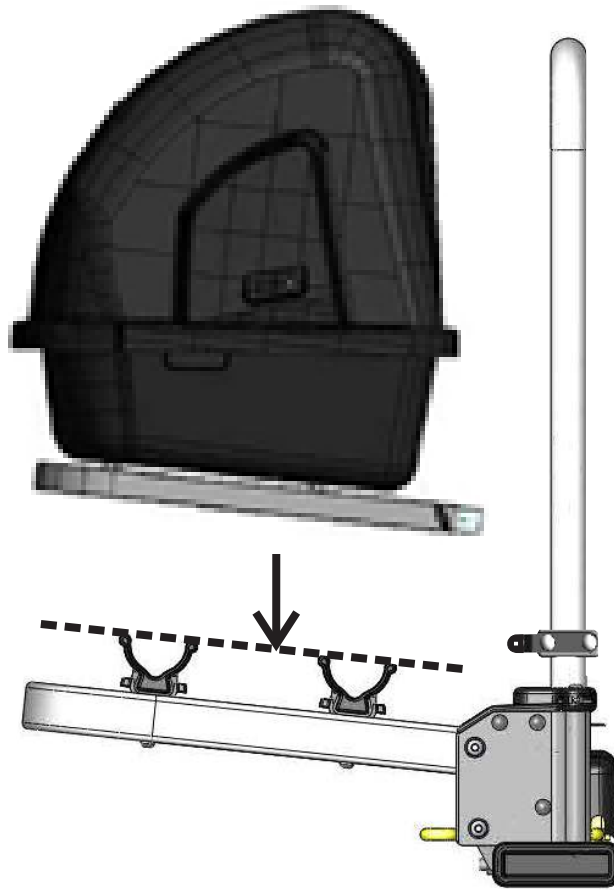

8

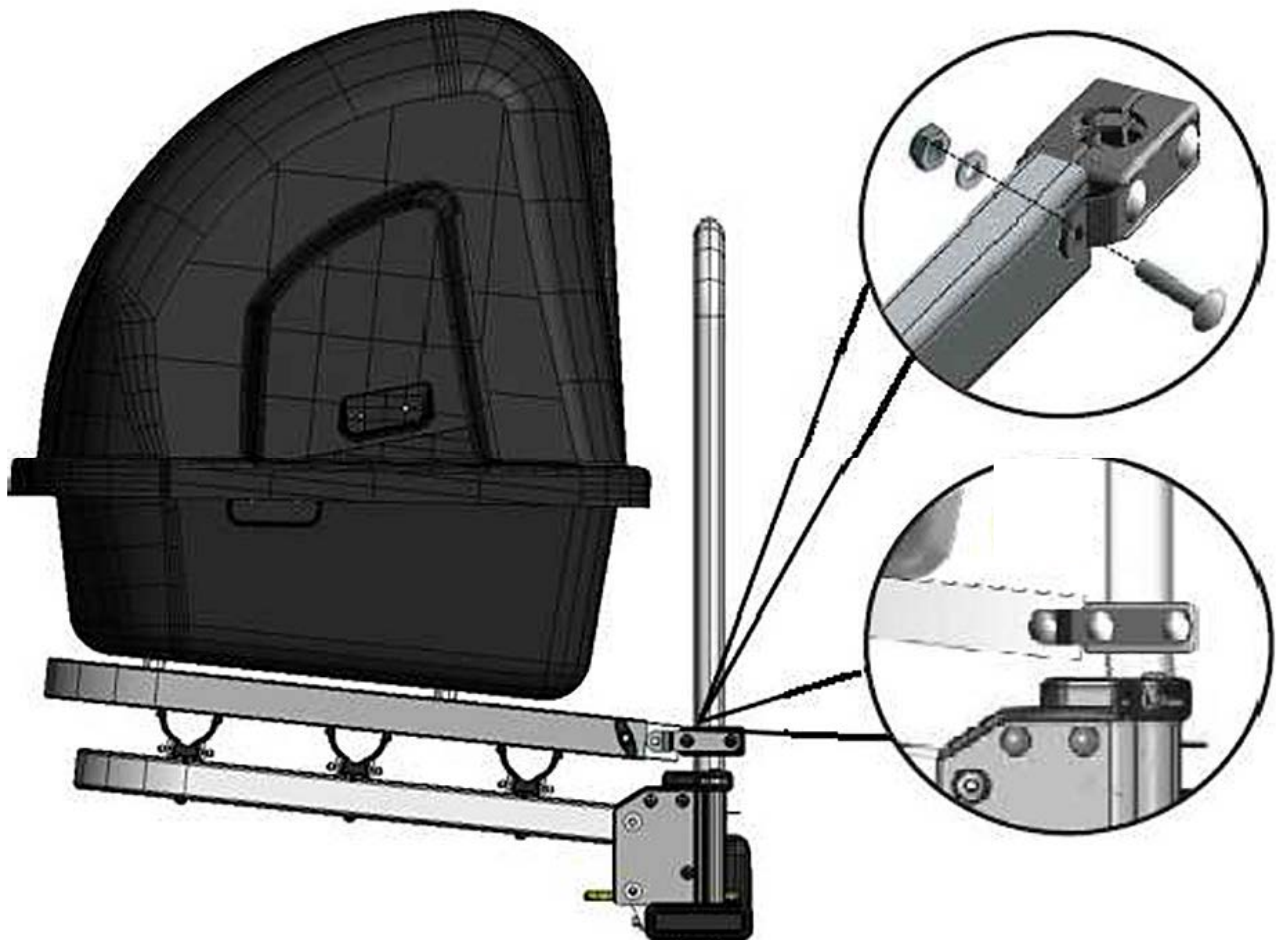

9

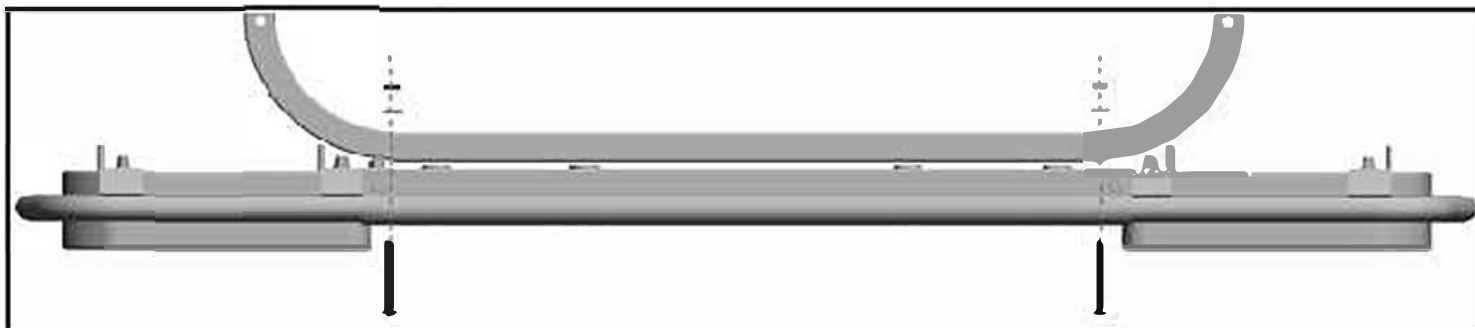
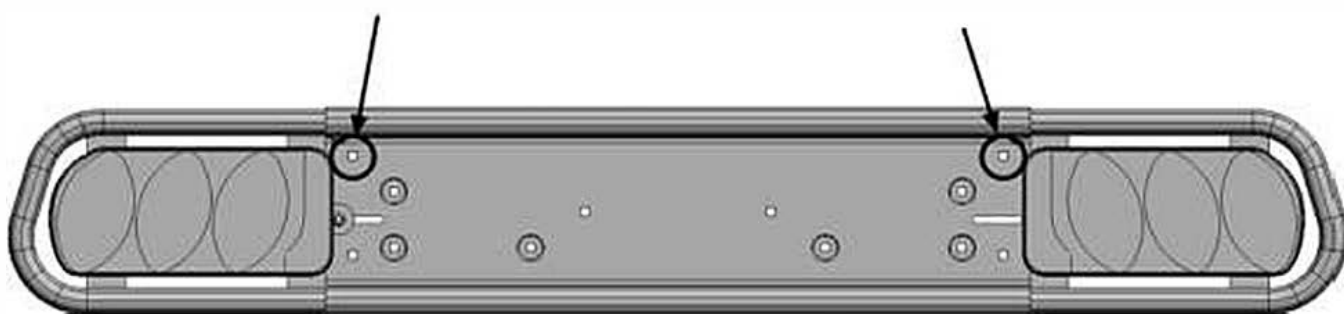
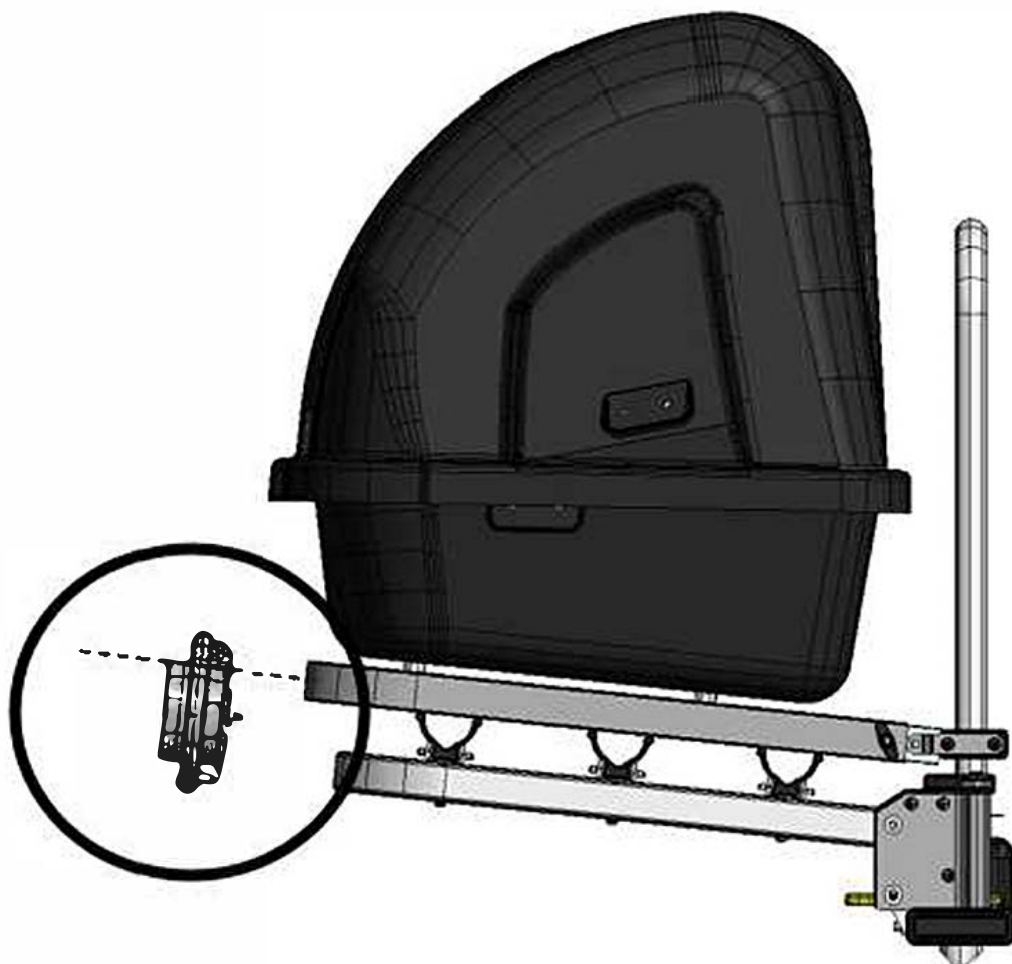



13

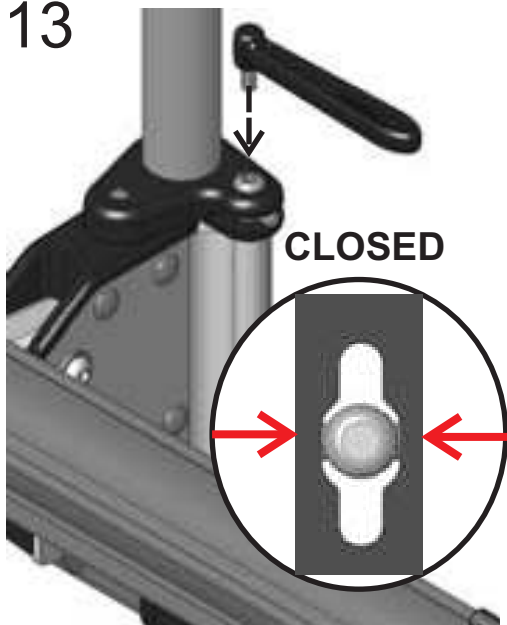

14

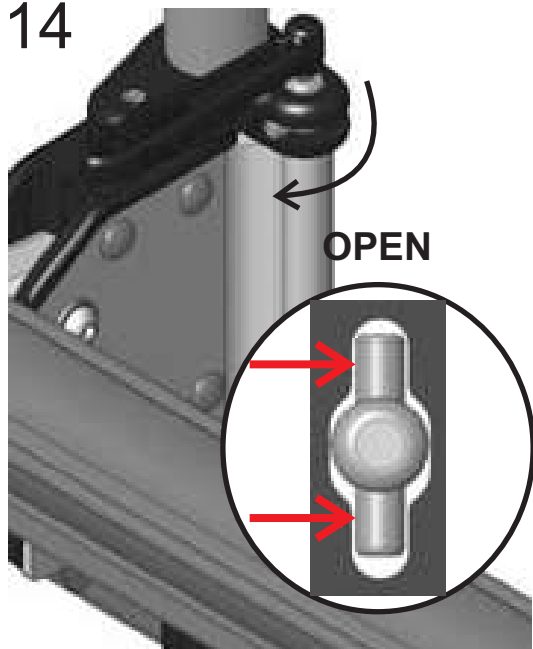

- (D) Die Absenkautomatik funktioniert über das Gewicht Box + Gepäcks (A).  
Ohne Gepäck die Box nach unten drücken (B)
- (GB) Automatic tip down only with the weight of the luggage (A).  
Without luggage press down on the Box (B)
- (I) Ribaltabile automaticamente solo con il peso dei Bagagli (A).  
Senza bagagli premere il Box verso il basso (B)

PRESS

- (F) Basculement automatique seulement avec le poids
- (NL) Alleen automatisch uitklapbaar onder het gewicht
- (E) Reclinable automáticamente sólo con el peso de las equipaje.  
Sin equipaje

**FABBRI PORTATUTTO srl**

Sede Legale Via Belvedere Fogliense, 575 - I - 47836 MONDAINO (RN)

Tel. ++39(0)309638801 - ++39(0)309638802 - Fax ++39(0)309980343 - e-mail: [Info@fababri.info](mailto:Info@fababri.info) - website: [www.fabbri.info](http://www.fabbri.info)